

# Telex Operating Instructions



**RadioCom™**

**BTR-80N, TR-80N, TR-82N**

**Professional  
Wireless  
Intercom System**

**TELEX®**



# Table of Contents

<b>1. Introduction</b>	
General Description . . . . .	1-1
System Features . . . . .	1-1
<b>2. BTR-80N Base Controls and Connections</b>	
Front Panel . . . . .	2-1
Rear Panel . . . . .	2-2
BTR-80N Specifications . . . . .	2-3
<b>3. TR-80N Controls and Connections</b>	
Top Panel . . . . .	3-1
Rear Panel . . . . .	3-2
TR-80N Specifications . . . . .	3-3
<b>4. TR-82N Beltpack Controls and Connections</b>	
Top Panel . . . . .	4-1
Rear Panel . . . . .	4-2
TR-82N Specifications . . . . .	4-3
<b>5. Initial Set-Up</b>	
Unpacking . . . . .	5-1
Antennas . . . . .	5-2
Antenna Connection . . . . .	5-2
Antenna Polarization . . . . .	5-2
Distance Between Antennas . . . . .	5-2
Antenna Placement . . . . .	5-2
Improving Reception/Increasing Range . . . . .	5-4
<b>6. BTR-80N Operation</b>	
Basic Operational Description . . . . .	6-1
System Quick Start . . . . .	6-1
Interfacing to the BTR-80N	
Transmit and Receive Antennas . . . . .	6-2
2-Wire Intercom Ports . . . . .	6-2
4-Wire Intercom Ports . . . . .	6-3
Auxiliary Input / Output . . . . .	6-3
Stage Announce (SA) Relay . . . . .	6-4
Base Station Link . . . . .	6-4
WTA Audio . . . . .	6-5
CAN Bus . . . . .	6-5
Program Jack . . . . .	6-5
Powering the Base Station . . . . .	6-6
Start-Up Screen . . . . .	6-6
Status Screen . . . . .	6-6
RSSI Screen . . . . .	6-6
Group / Channel Selection . . . . .	6-7
Group / Channel Select . . . . .	6-7
Group / Frequency Select . . . . .	6-7
Frequency Edit (User-Defined Groups Only) . . . . .	6-7
Base Main Settings . . . . .	6-8
Talk Button . . . . .	6-8
Channel Select Button . . . . .	6-8
Local Headset Volume and Gain . . . . .	6-8
Base Transmit Power . . . . .	6-8
Squelch Settings . . . . .	6-9
Stage Announce Level . . . . .	6-9
Antenna Power . . . . .	6-9
CAN Bus Number . . . . .	6-10

## Table of Contents (continued)

Intercom Settings . . . . .	6-10
i. 2-Wire Intercom . . . . .	6-10
ii. 4-Wire Intercom . . . . .	6-11
Auxiliary Settings . . . . .	6-11
ClearScan . . . . .	6-12
Lockout . . . . .	6-12
Copy . . . . .	6-12
1 <sup>st</sup> Use Default . . . . .	6-12
Factory Reset . . . . .	6-12
Connection of Multiple Base Stations with Link Cables . . . . .	6-13
Over-the-Air Data Links . . . . .	6-13
Master and Servant Base Stations . . . . .	6-14
CAN Bus . . . . .	6-15
Base Station Link Configurations . . . . .	6-15
Wireless Talk Around (WTA) Audio Only . . . . .	6-16
WTA and a Single Can Bus Network . . . . .	6-17
WTA and Several CAN Bus Networks . . . . .	6-18
<b>7. TR-80N / TR-82N Operation</b>	
Basic Operational Description . . . . .	7-1
System Quick Start . . . . .	7-1
Battery Installation . . . . .	7-2
Headset Connection . . . . .	7-3
Sidetone . . . . .	7-3
Antenna Connections . . . . .	7-3
TR-80N Beltpack . . . . .	7-4
ON/Off Volume Control . . . . .	7-4
BAT/Peak Light . . . . .	7-4
Talk Button . . . . .	7-4
Audio Channel Select Button . . . . .	7-4
Stage Announce (SA) . . . . .	7-4
Group and Channels . . . . .	7-5
Transmit Frequency . . . . .	7-5
Receive Frequencies . . . . .	7-6
Microphone Gain . . . . .	7-6
Battery Display . . . . .	7-6
Transmit Power . . . . .	7-7
Squelch Screen . . . . .	7-8
Transmit Mode . . . . .	7-8
LEDs Off/On . . . . .	7-8
Software Version/Band . . . . .	7-8
ClearScan™ . . . . .	7-9
Lock Out . . . . .	7-9
1st Use Default . . . . .	7-9
Factory Reset . . . . .	7-9
RF Monitor Screen . . . . .	7-9
Setting Beltpack ID . . . . .	7-10
TR-82N Beltpack . . . . .	7-11
On/Off Volume Control . . . . .	7-11
BAT/Peak Light . . . . .	7-11
Talk Buttons . . . . .	7-11
Audio Channel Select Button . . . . .	7-11
Stage Announce (SA) . . . . .	7-11
Wireless Talk Around (WTA) . . . . .	7-11
Group and Channels . . . . .	7-12
Transmit Frequency . . . . .	7-12

## Table of Contents (continued)

Receive Frequencies .....	7-13
Microphone Gain .....	7-13
Battery Display .....	7-13
Transmit Power .....	7-14
Squelch Screen .....	7-15
Transmit Mode .....	7-15
Headphone Options .....	7-15
Auxiliary Input .....	7-15
LEDs Off/On .....	7-15
Software Version/Band .....	7-16
ClearScan™ .....	7-16
Lock Out .....	7-16
1st Use Default .....	7-16
Factory Reset .....	7-16
RF Monitor Screen .....	7-17
Setting Beltpack ID .....	7-17
<b>8. BTR-80N Menu Structure .....</b>	<b>8-1</b>
<b>9. TR-80N Menu Structure .....</b>	<b>9-1</b>
<b>10. TR-82N Menu Structure .....</b>	<b>10-1</b>
<b>11. Frequency Bands .....</b>	<b>11-1</b>
Band Pairings .....	11-1
Frequency Plan .....	11-2
<b>12. Trouble Shooting .....</b>	<b>12-1</b>
<b>13. Battery Information .....</b>	<b>13-1</b>
<b>14. 2 -Wire Intercom Specifications .....</b>	<b>14-1</b>
<b>15. Certification Information .....</b>	<b>15-1</b>
FCC .....	15-1
Canada .....	15-1
<b>16. Accessories and Replacement Parts .....</b>	<b>16-1</b>

# Section 1

## Introduction

### General Description

Telex RadioCom™ BTR-80N UHF Synthesized Wireless Intercom system offers reliable, high-performance, high-fidelity full-duplex communications delivered with minimum spectrum usage.

The BTR-80N system includes the BTR-80N frequency agile base station, working with up to four TR-80N or TR-82N frequency agile beltacks operating in full-duplex communications. An almost unlimited number of beltacks may be used with a base station if the beltacks are in Push-to-Tx mode (half-duplex).

The BTR-80N system incorporates two audio channel operation, permitting the beltack operator to choose between two separate audio channels of communication, with the base station tracking the beltack selection. This allows the user the flexibility to create a party-line and a private line within the same beltack.

The BTR-80N system is perfectly suited for stand-alone operation and can also interface with Audiocom® (Telex), RTS® TW, Clear-Com®, as well as RTS®, Matrix systems and other 4-wire intercom systems. In addition to the external intercom systems interfaces listed above, the system provides connections for auxiliary balanced audio input and output, as well as wireless talk-around (WTA) and stage announce (SA) features.

The RadioCom™ BTR-80N system has been designed for reliable, efficient operation. Operating in the 482 to 722 MHz range the units operate reliably at line-of-sight distances of 1,000 feet. With available antenna systems from Telex, the effective operating range can be extended. The high-efficiency beltacks provide between 8 and 11 hours of uninterrupted operation using NiMH rechargeable battery packs.

### System Features

- Frequency-agile base station and beltacks. No external computer/device required to select frequencies.
- Backlit base-station LCD allows the user to easily monitor the beltack's status as well as change base station frequencies.
- Squelch adjust on BTR-80N and TR-80N, TR-82N beltacks.
- Beltack's battery level displayed on the base station and in beltack's menus.
- ClearScan™ function on base station and beltack to automatically find the best channels on which to operate.
- Full-duplex (simultaneous talk and listen) or Push-to-TX (half-duplex) operation.
- Compatible with Audiocom® (Telex), RTS® TW, Matrix, Clear-Com® , and other wired intercom types.
- Two independent channels of intercom audio with the ability to operate partyline and RTS Matrix on the same intercom channel at the same time.
- WTA (Wireless Talk Around) beltack control. This feature allows beltacks to talk to each other, but their audio is lifted from any wired system connected to the base station.
- SA (Stage Announce) beltack control. Allows the user to direct their audio to a jack on the back of the base for P.A. systems or other external audio systems.
- Relay contact closure on the base when the SA button is pressed.
- TR-82N features two audio channel binaural operation in either stereo or mono mode.
- TR-82N has 1/8 inch (3.5mm) jack for auxiliary input from another audio source, such as an IFB, iPod®, or other similar device.
- Beltack units contained in a weather and shock resistant die cast magnesium case.
- Convenient IEC power connector on the base station so the unit can plug directly to outlets. No in-line or wall plug power supply.
- Base station has option for DC on the receive coaxial cable line for powering in-line low noise amps.
- Dark mode settable on TR-80N and TR-82N beltacks. This shuts down all LEDs.

RTS® and Audiocom® are registered trademarks of Telex Communications, Inc.  
Clear-Com® is a registered trademark of Clear-Com Intercom Systems, Inc  
iPod® is a registered trademark of Apple Inc..

# Section 2

## BTR-80N Base Station

### Controls and Connections - Front Panel

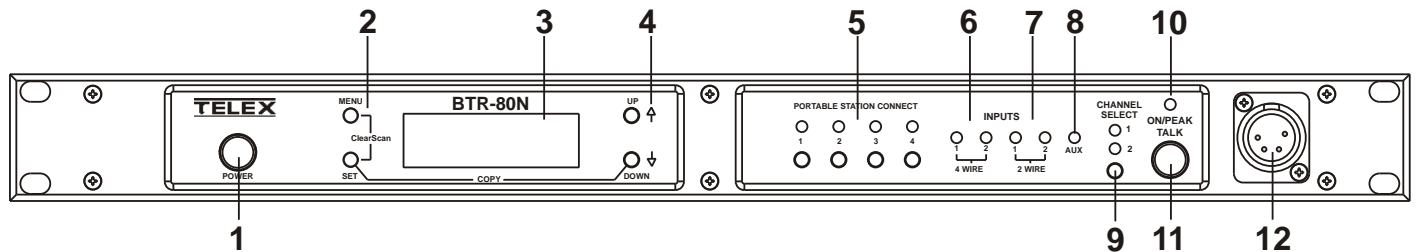


Figure 2-1  
BTR-80N - Front Panel

1. **Power switch** – Do not power-up a base station within 3 seconds of the unit being turned off. Voltages within the unit need to drop below a threshold before being re-powered. If power-up in less than 3 seconds, the unit may boot as the wrong frequency band.
2. **[Menu] and [Set] buttons** – Used to select menus and set options on the LCD.
3. **Backlit Graphics LCD (Liquid Crystal Display).**
4. **[Up] and [Down] buttons** – Used to select base station options on the LCD.
5. **Portable Station Connect** – Buttons used to enable or disable the respective receiver's audio. GREEN LED = Audio enabled, LED OFF = Audio disabled.
6. **4-wire Selection/Peak Input Indicators** - Displays when 4-wire intercoms are active with a green indication. A red indication means the intercom input level is too high.
7. **2-Wire Selection/Peak Input Indicators** - Displays which 2-wire intercoms are active with a green indication. A red indication means the intercom input level is too high.
8. **Auxiliary Selection/Peak Input indicator** - Displays if auxiliary input is 'ON' with a green indication. A red indication means the intercom input level is too high
9. **Headset Intercom Select** – Controls the intercom to which the local headset is connected. Each press of the button changes the connection; channel 1, channel 2, both.
10. **Talk/Peak Light** – LED is green when talk button #11 is active. A normal mic gain setting will cause the LED to flash red on the loudest speech levels. If the gain is too high, the LED will be red at normal speech volumes.
11. **Talk Button** – Press to enable the audio path from the local headset. LED #10 will turn green when enabled. A quick press and release latches button on. If the talk function is latched on, pressing the talk button again will turn it off.
12. **Local Headset Connector** – Male XLR connector for Telex units, Female XLR connector for RTS units. A dynamic or electret headset microphone is automatically detected. Microphone gain and volume are settable in the software menus.

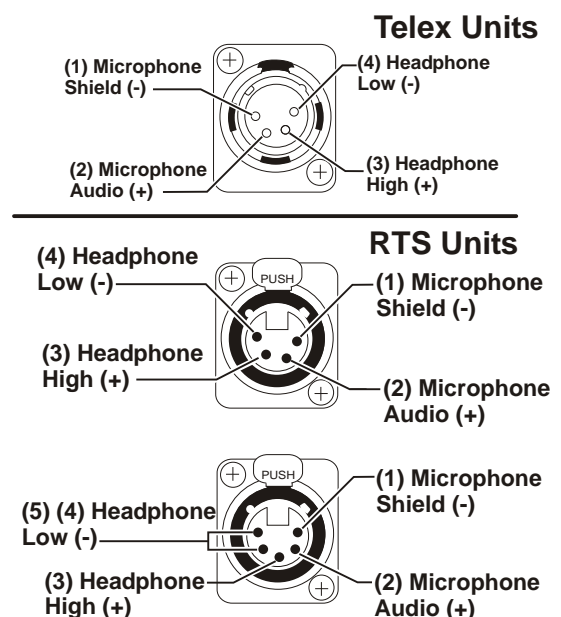
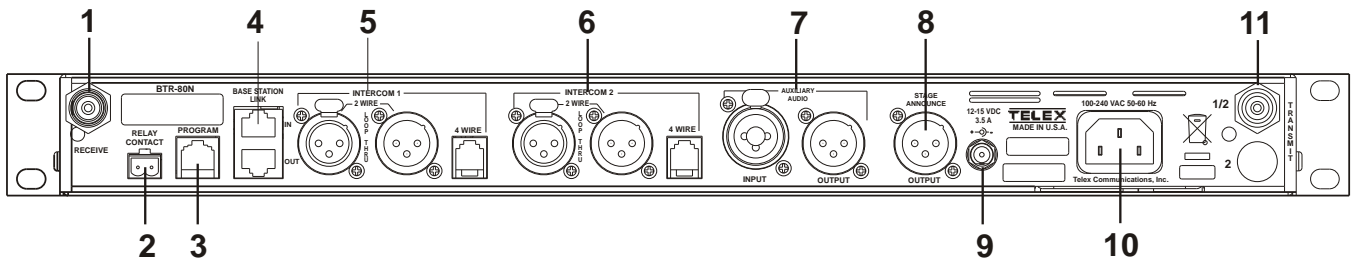


Figure 2-2  
Local Headset Wiring

## Controls and Connections - Rear Panel



**Figure 2-3**  
**BTR-80N - Rear Panel**

1. **Receive Antenna** - Female “TNC” Connector. Color band on antenna must match color dot on base station.
2. **Relay Contact** – A dry contact closure which is activated when a beltpack user presses the stage announce (SA) button. Normally Open (NO). The rating is one amp at 24V maximum.
3. **Program Connector** - Used to update software in unit.
4. **Base Station Link Jacks** – When multiple base stations are connected through this jack, it allows wireless talk around (WTA) audio from the beltpacks to be routed from system to system. Also will allow CAN bus data to be passed between base stations.
5. **Intercom 1** – Interface to wired intercom channel 1.
  - 2-Wire** – Male and female 3-pin XLR connectors wired in parallel. The connectors are switched to the appropriate intercom configuration via software.
  - 4-Wire** – An RJ-11 type jack compatible with “Matrix” type intercom systems.
6. **Intercom 2** – Interface to wired intercom channel 2.
  - 2-Wire** – Male and female 3-pin XLR connectors wired in parallel. The connectors are switched to the appropriate intercom configuration via software.
  - 4-Wire** – An RJ-11 type jack compatible with “Matrix” type intercom systems.
7. **Auxiliary Input/Output** – One 3-pin female XLR/ 1/4 inch combination input connector and one 3-pin male XLR output connector.
8. **Stage Announce Output** – Passes the audio from any of the base station’s beltpacks that have selected stage announce (SA).
9. **DC Input Jack** – Accepts 12-15 VDC (5.5mm by 2.5mm screw on plug), 3.5 Amps to power base station from a D.C. source. Base may be connected to DC and AC source at the same time. If AC source fails the base will automatically switch to D.C. power.
10. **Power** – IEC receptacle. Accepts 100 – 240 VAC, 50 – 60 Hz.
11. **Transmit Antenna** - Female “TNC” Connector. Color band on antenna must match color dot on base station.



# BTR-80N Specifications

## Overall

RF Frequency Range	482 - 608 MHz, 614 - 722 MHz, in 18 MHz TX and RX bands (Some frequencies only available in certain countries)
Power Requirements	100-240 VAC, 50-60 Hz, IEC receptacle
DC Only	12 - 15 VDC, 3.5 Amps
Temperature Range	-4° F to 130° F (-20° C to 55° C)
Dimensions	19.00" W x 1.72" H x 14.00" D (48.3 cm x 4.4 cm x 35.6 cm)
Weight	7 lbs 2 oz (3.24 kg)
TX Antenna	½ Wave (supplied), TNC Male Connector
RX Antenna	½ Wave (supplied), TNC Male Connector
FCC ID:	B5DM528 (TX 482-608 MHz)
Frequency Response	200Hz-4kHz
Four Wire Input	Level Adjustable (2 Vrms typical)
Four Wire Output	Level Adjustable (2 Vrms typical)
Telex Intercom	Input/Output Level Adjustable (1 Vrms typical), Line impedance 300
RTS Intercom	Input/Output Level Adjustable (0.775 Vrms typical), Line Impedance 200
Clear-Com® Intercom	Input/Output Level Adjustable (1 Vrms typical), Line Impedance 200
Auxiliary Input	Adjustable (2 Vrms typical)
Auxiliary Output	Adjustable (2 Vrms typical into 600 )
Stage Announce Output	Internally Adjustable (2 Vrms typical at rated deviation into 600 )
Stage Announce Relay	Dry contact, rated at 1 Amp, 24V Max
Microphone input sensitivity	9mV
Local Headset Output	40mW output into 600 (1% Distortion)

## Transmitter

Type	Two Synthesized Transmitters, 720 channels each
Transmit Power (each transmitter)	Selectable: off, 10 mW, 50 mW, 100 mW, 249 mW
Modulation Type	FM
Deviation	4 kHz
RF Frequency Stability	2.5 PPM
Modulation Limiter	Peak-Responding Compressor
Radiated Harmonics & Spurious	Exceeds FCC specifications

## Receiver

Type	Triple Conversion Superheterodyne, four Independent Synthesized IFs, FM, 720 channels each
RF Sensitivity	<0.6 µV for 12 dB SINAD
Squelch Threshold	adjustable - 12 / 20 / 24 dB SINAD
IF Selectivity	6 dB at 30 kHz Bandwidth
Image Rejection	70 dB or better
Squelch Quieting	90 dB
RF Frequency Stability	2.5 PPM



# Section 3

## TR-80N Beltpack

### Controls and Connections - Top Panel

---

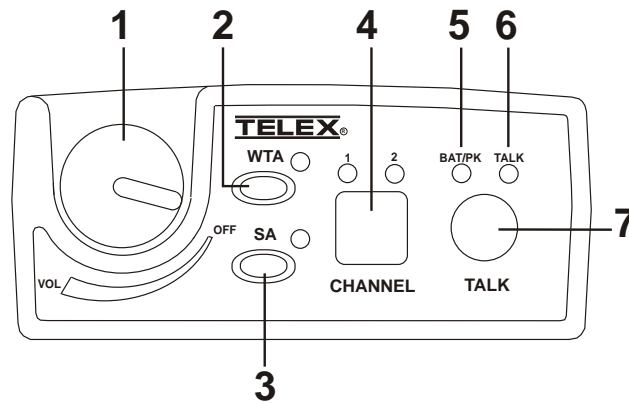


Figure 3-1  
TR-80N Top Panel

- 1. On/Off & Volume Control** – Turns the beltpack power on and controls headset volume.
- 2. Wireless Talk Around (WTA)** – When pressed, the user's audio is disconnected from the wired intercom, auxiliary input/output and the base station's local headset. Other beltpack users, on that audio channel, can hear the user as normal. The button activates the nearby red LED as well as the talk button.
- 3. Stage Announce (SA)** – When pressed, the user's audio is routed to the stage announce connector on the back of the base station. The user also loses their sidetone as an indication that stage announce is activated. The other wireless beltpacks and wired users do not hear the user's audio. The button is non-latching and activates the nearby red LED as well as the talk button.
- 4. Audio Channel Select Button** – Allows user to select either audio channel 1 or 2.
- 5. Bat/Peak Light (BAT/PK)** – Light will flash once when unit is turned on if the battery is good. If the light stays on, battery is low. If the light does not flash, battery is dead. A normal microphone gain setting will cause the LED to flash for some of the words at normal speech levels. If the gain is too high, the LED will be red during all words at normal speech levels.
- 6. Talk Light** – LED is on when the talk button, SA or WTA is active.
- 7. Talk button** – Press to enable the audio path from the local headset microphone. The "TALK" LED, #6, will turn red when enabled. A quick press and release latches the talk function, unless latching has been disabled. Holding the button for over ½ a second will cause the audio path to be enabled only for as long as the button is held. If the talk function is latched on, pressing the talk button again will turn it off.

## Controls and Connections - Rear Panel

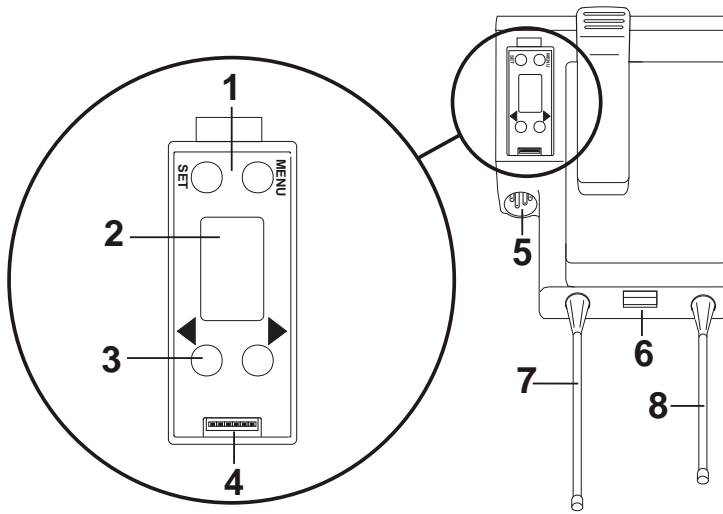
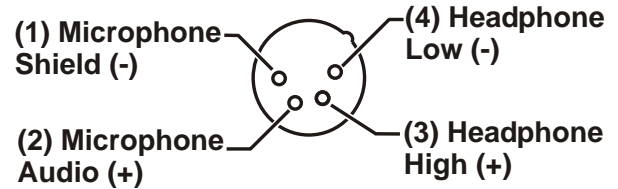


Figure 3-2  
TR-80N Rear Panel/Connector/Antennas

1. **[MENU] and [SET] buttons** – Used to select menus and set options on the LCD.
2. **LCD (Liquid Crystal Display)**
3. **[UP] and [DOWN] buttons** – Used to select beltpack options on the LCD.
4. **Programming Connector** – Used to update software in unit.

5. **Headset Connector** – Male XLR connector for Telex units, Female XLR connector for RTS units. A dynamic or electret headset microphone is automatically detected by the beltpack and a bias voltage supplied if needed.

### Telex Units



### RTS Units

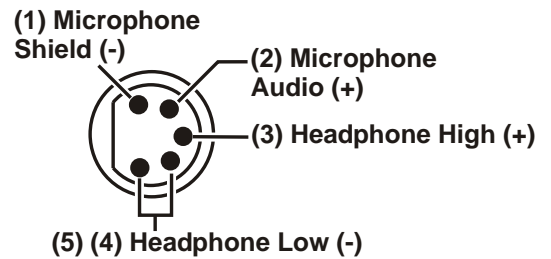
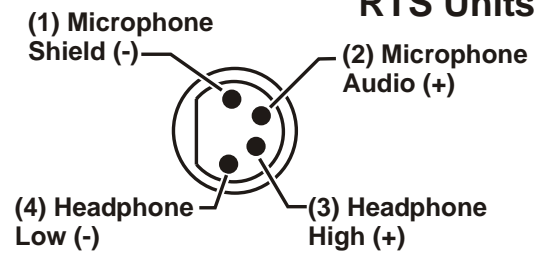


Figure 3-3  
Headset Jack Wiring

6. **Battery Latch** – Press down to release the battery pack. While holding the latch down, slide the battery pack about 1/8 inch back toward the latch, until it stops, then lift it out.
7. **Receive Antenna** – Screw type 1/4-wave replaceable antenna. The color dot on the screw end of the antenna must match color dot on antenna receptacle.
8. **Transmit Antenna** – Screw type 1/4-wave replaceable antenna. Color dot on the screw end of the antenna must match color dot on antenna receptacle.

**NOTE:** Microphone gain and transmit mode is set via software menus.

## TR-80N Specifications

RF Frequency Range . . . . .	482 - 608 MHz, 614 - 722 MHz, in 18 MHz TX and RX bands (Some frequencies only available in certain countries)
Power Requirements. . . . .	6 "AA" Cells Alkaline (NiMH optional)
Current Draw . . . . .	200 mA (Push-to-Talk, Talk On)
Temperature Range . . . . .	-4° F to 130° F (-20° C to 55° C)
Dimensions . . . . .	3.75"W x 5.05"H x 1.65" D (9.5 cm x 12.8 cm x 4.2 cm)
Weight . . . . .	16 oz (454g) with alkaline batteries
TX Antenna. . . . .	1/4 Wave (supplied), Screw type, Replaceable
RX Antenna . . . . .	1/4 Wave (supplied), Screw type, Replaceable
FCC ID: . . . . .	B5DM530 (TX 608-698 MHz)
Frequency Response . . . . .	200Hz-4kHz
Microphone input sensitivity . . . . .	7 mV
Local Headset Output . . . . .	40 mW output into 600 (1% distortion)

### Transmitter

Type . . . . .	Synthesized, 720 channels
Transmit Power . . . . .	Selectable: Auto, 5, 50, 100 mW
Modulation Type. . . . .	FM
Deviation. . . . .	4 kHz
RF Frequency Stability. . . . .	2.5 PPM
Modulation Limiter . . . . .	Peak-Responding Compressor
Radiated Harmonics & Spurious . . . . .	Exceeds FCC specifications

### Receiver

Type . . . . .	Triple Conversion Superheterodyne, Synthesized, FM, 720 channels
RF Sensitivity . . . . .	<0.6 $\mu$ V for 12 dB SINAD
Squelch Threshold . . . . .	adjustable - 12 / 20 / 24 dB SINAD (About 1.0 V)
IF Selectivity . . . . .	6 dB at 30 kHz Bandwidth
Image Rejection . . . . .	70 dB or better
Squelch Quieting. . . . .	90 dB
RF Frequency Stability. . . . .	2.5 PPM



### Controls and Connections - Top Panel

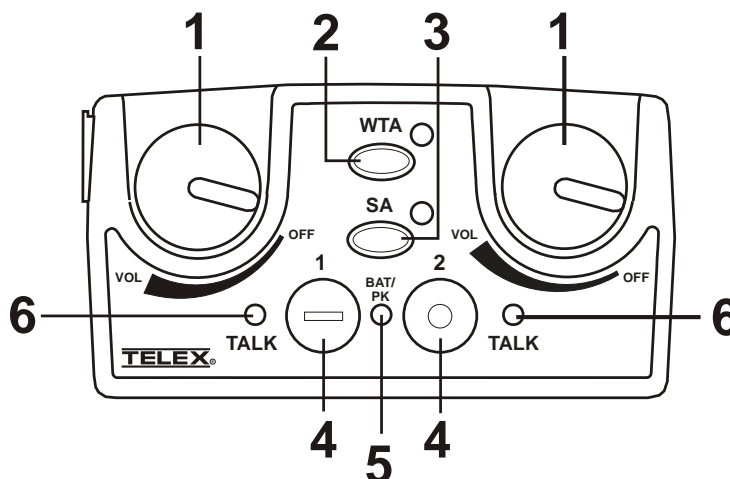
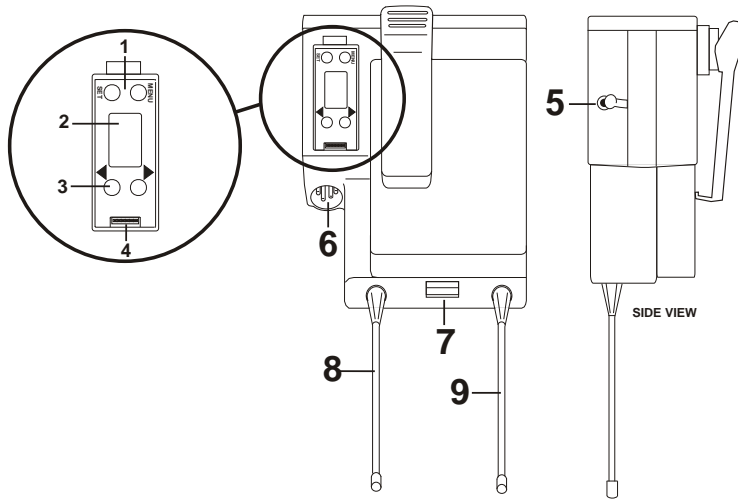


Figure 4-1  
TR-82N Top Panel

1. **On/Off and Volume Control** - Turns beltpack power on and controls headset volume for intercom channels "1" and "2". Either knob, "1" or "2", turns the beltpack on. Both knobs must be off to turn the beltpack off. If only one knob is on, then that intercom channel, "1" or "2" is on for both transmit and receive audio.
2. **Wireless Talk Around (WTA)** - When pressed, the user's audio is disconnected from the wired intercom, auxiliary input/output and the base station's local headset. Other beltpack users, on that audio channel, can hear the user as normal. The default setting is software selectable, as to which intercom channels, "1", "2", "1 + 2", or currently selected channel, is activated along with the "WTA" button. The "WTA" button activates the nearby red LED as well as the software selected intercom channels "TALK" LED if not already active.
3. **Stage Announce (SA)** - When pressed, the user's audio is routed to the stage announce connector on the back of the base station. The user also loses their sidetone as an indication that stage announce is activated. The other wireless beltpacks and wired users do not hear the user's audio. The button is non-latching and activates the nearby red LED.
4. **Talk Button** - Press to enable the audio path to either intercom channels "1", "2" or "1 + 2", from the local headset microphone. The associated "TALK" LED, #6, will turn red when enabled. A quick press and release latches the talk function, unless latching has been disabled. Holding the button for over ½ second will cause the audio path to be enabled only for as long as the button is held. If the talk function is latched on, pressing the talk button again will turn it off.
5. **Low Battery/Peak (BAT/PK) Light** - Light will flash once when unit is turned on if the battery is good. If the light stays on, battery is low. If the light does not flash, battery is dead. A normal microphone gain setting will cause the LED to flash for some words at normal speech levels. If the gain is too high, the LED will be red during all words at normal speech levels.
6. **Talk Light** - Will turn red when enabled by associated "TALK" or "WTA" button.

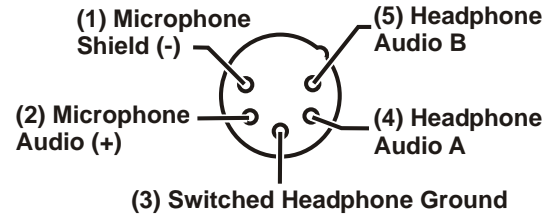
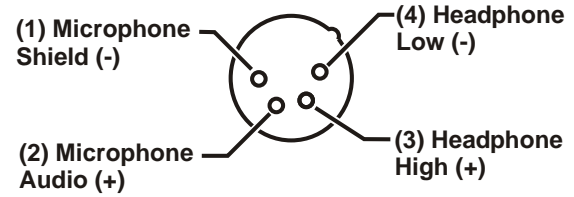
## Controls and Connections - Rear Panel



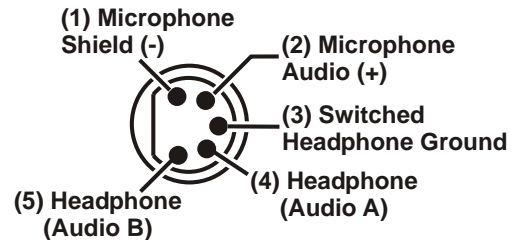
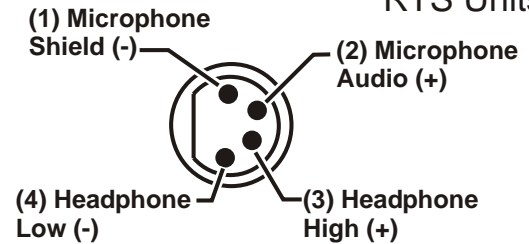
**Figure 4-2**  
**TR-82N Rear Panel/Connector/Antennas**

1. **[MENU] and [SET] buttons** – Used to select menus and set options on the LCD.
2. **LCD (Liquid Crystal Display)**
3. **[UP] and [DOWN] buttons** – Used to select beltpack options on the LCD.
4. **Programming Connector** - Used to update software in unit.
5. **Auxiliary Input Audio Jack** -1/8" (3.5mm) mono input jack. Local only to beltpack.
6. **Headset Connector** – Male XLR connector for Telex units, Female XLR connector for RTS units. A dynamic or electret headset microphone is automatically detected by the beltpack and a bias voltage supplied if needed. Four pin Telex/RTS units are monaural. Five pin Telex/RTS units have a software set-up to select if XLR pin 3 or 5 is the channel 2 output and if pin 3 is ground.

### Telex Units



### RTS Units



**Figure 4-3**  
**Headset Jack Wiring**

7. **Battery Latch** – Press down to release the battery pack. While the latch is held down, slide the battery pack about 1/8 inch back, toward the latch, until it stops, then lift it out.
8. **Receive Antenna** – Screw type 1/4-wave replaceable antenna. The color dot on the screw end of the antenna must match color dot on antenna receptacle.
9. **Transmit Antenna** – Screw type 1/4-wave replaceable antenna. The color dot on the screw end of the antenna must match color dot on antenna receptacle.

**NOTE: Microphone gain and transmit mode is set via software menus.**



## **TR-82N Specifications**

RF Frequency Range . . . . .	482 - 608 MHz, 614 - 722 MHz, in 18 MHz TX and RX bands (Some frequencies only available in certain countries)
Power Requirements . . . . .	6 "AA" Cells Alkaline (NiMH optional)
Current Draw . . . . .	280 mA (Push-to-Talk, A and B Talk On)
Temperature Range . . . . .	-4° F to 130° F (-20° C to 55° C)
Dimensions . . . . .	3.75" W x 5.35" H x 2.02" D (9.5 cm x 13.5 cm x 5.1 cm)
Weight . . . . .	21 oz (595g) with alkaline batteries
TX Antenna . . . . .	1/4 Wave (supplied), Screw type, Replaceable
RX Antenna . . . . .	1/4 Wave (supplied), Screw type, Replaceable
FCC ID: . . . . .	B5DM531 (TX 608-698 MHz)
Frequency Response . . . . .	200Hz-4kHz
Microphone input sensitivity . . . . .	7 mV
Local Headset Output . . . . .	40 mW output into 600          distortion)

### **Transmitter**

Type . . . . .	Synthesized, 720 channels
Transmit Power . . . . .	Selectable: Auto, 5, 50, 100 mW
Modulation Type . . . . .	FM
Deviation . . . . .	4 kHz
RF Frequency Stability . . . . .	2.5 PPM
Modulation Limiter . . . . .	Peak-Responding Compressor
Radiated Harmonics & Spurious . . . . .	Exceeds FCC specifications

### **Receiver**

Type . . . . .	Two, Triple Conversion Superheterodyne Receivers, Synthesized, FM, 720 channels
RF Sensitivity . . . . .	<0.6 $\mu$ V for 12 dB SINAD
Squelch Threshold . . . . .	adjustable - 12 /20 /24 dB SINAD
IF Selectivity . . . . .	6 dB at 30 kHz Bandwidth
Image Rejection . . . . .	70 dB or better
Squelch Quieting . . . . .	90 dB
RF Frequency Stability . . . . .	2.5 PPM



# Section 5

## Initial Equipment Set-Up

---

### Unpacking

Unpack your RadioCom™ System. Below are the items that should come with your base station and each belt pack.

Contact the shipper or your dealer immediately if anything is damaged or missing.

#### **BTR-80N**

Quantity	Description
1	BTR-80N Base Station
1	Operating Instructions
1	Power Cord
2	Antennas (one Transmit and one Receive)
1	Warranty Card
1	2 terminal plug (for SA Relay)
4	Rubber feet

#### **TR-80N, TR-82N**

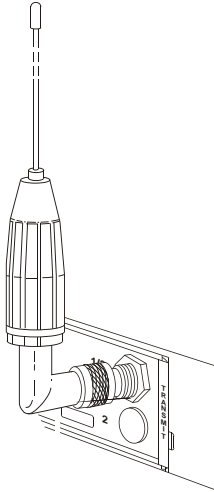
Quantity	Description
1	TR-80N or TR-82N with Antennas
1	Battery pack
1	Quick Start Card
1	Warranty Card
1	Belt Clip
1	LCD Cover

## Antenna Connection

The base station is supplied with two (2) antennas. One 1/2-wave antenna for Transmit and one 1/2-wave for Receive. The antennas have TNC male connectors.

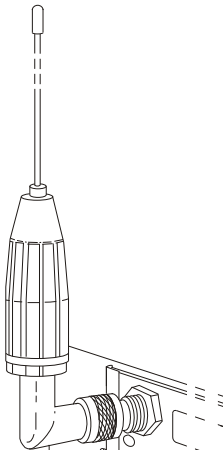
The frequency range of the antennas should match the receiver and transmitter of the base station. Match the color code on the antenna with the color code on the base station.

Attach the transmit 1/2-wave antenna to the antenna input receptacle labeled "Transmit" on the right side of the rear panel. The antenna should be vertically aligned.



**Figure 5-1**  
Attaching Transmit 1/2-Wave Antenna

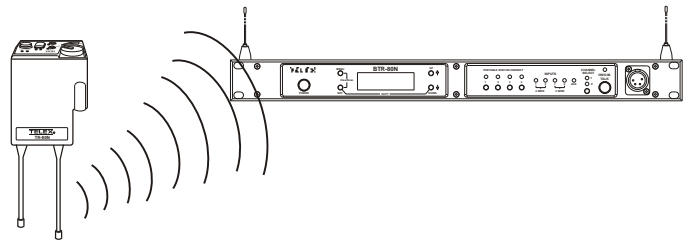
Attach the receive 1/2-wave antenna to the antenna input receptacle labeled "Receive" on the left side of the rear panel. The antenna should be vertically aligned.



**Figure 5-2**  
Attaching Receive 1/2-Wave Antenna

## Antenna Polarization

The Telex Wireless Intercom System is "Vertically Polarized". This means both the transmitting and receiving antennas should operate in the vertical position.



ANTENNAS SHOULD BE VERTICAL

**Figure 5-3**  
Vertically Polarized Antennas

## Distance between Antennas

The distance between the base station's receive and transmit antennas is not adjustable when the antennas are connected directly on the back of the unit.

The antennas can be remotely mounted for a better signal path. A Telex coax assembly with remote antennas may be required. See "Accessory" section for ordering information.

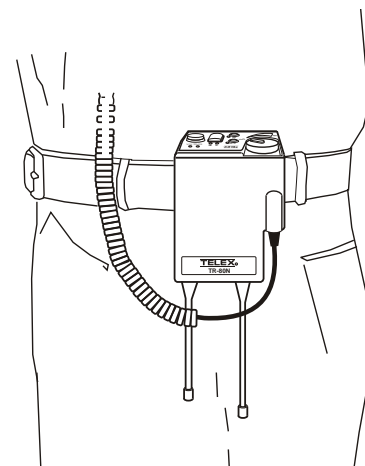
**NOTE:** If your base station is to be located in a shielded rack mount enclosure or other poor RF location, you must remotely mount the 1/2-wave antennas with coax assemblies. See "Accessories and Replacement Parts" section for remote mounting hardware.

## Antenna Placement

Proper antenna placement probably has the most effect on your TELEX Wireless Intercom System's overall performance. The following suggestions will result in optimum performance.

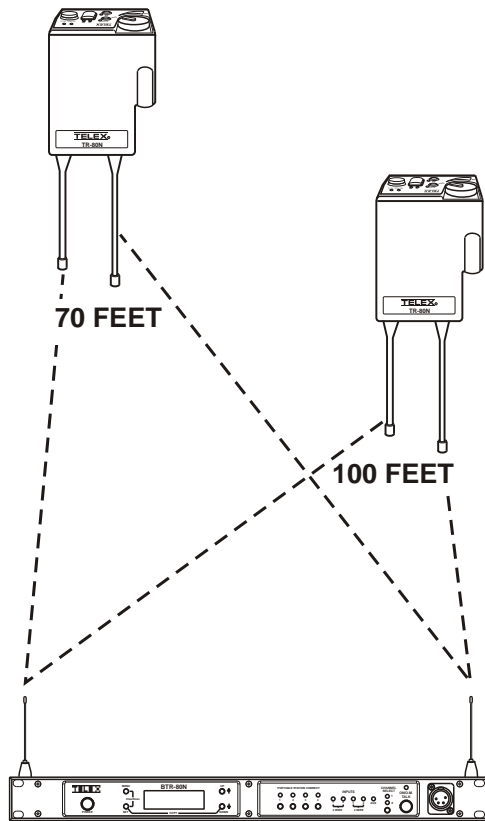
Proper placement of the belt pack can be critical. The antennas should be in the open. Bending the antennas up and placing the belt pack in a pocket, etc., will reduce system distance.

It is suggested that the unit be worn on the belt or pocket with both antennas vertical for best operating range and performance.

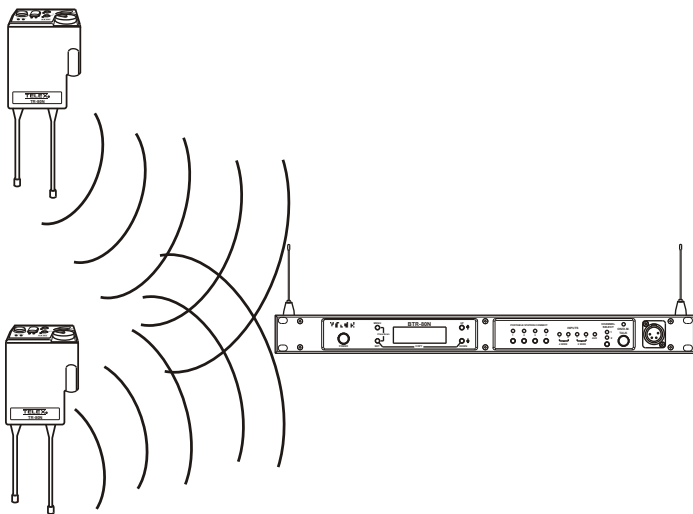


**Figure 5-4**  
Proper Dressing of the Antennas

Keep the distance between the base station and the beltacks as short as possible. The greater the distance, the weaker the signal. Make sure the “signal paths” between the base station and beltacks are unobstructed. You should be able to visibly locate the base station antennas at all times for best performance.

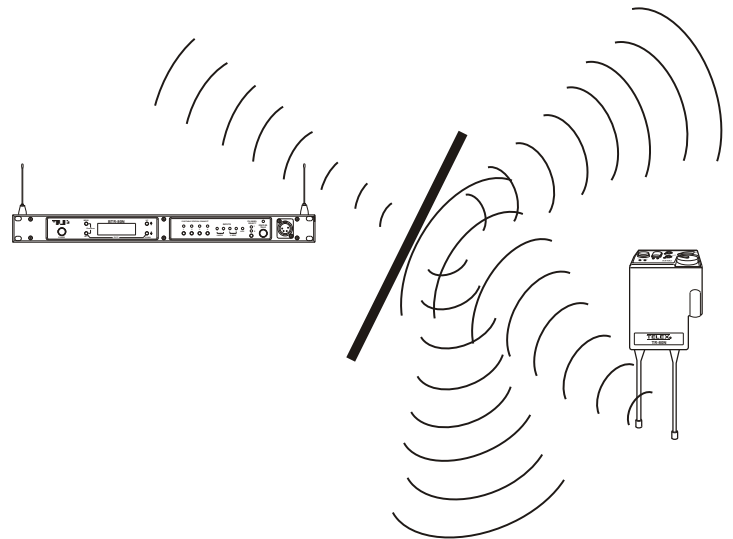


**Figure 5-5**  
Distance Between base station and beltack



**Figure 5-6**  
Keeping Site Clear to Antenna

Attempting to operate the wireless intercom system through or around walls, ceilings, metal objects, etc. will reduce system range and performance.



**Figure 5-7**  
Operating System Near Obstructions

**DO NOT** - mount the base station 1/2-wave antennas on, or next to metal, such as beams, walls with metal studs, equipment racks, etc. This also applies to the antennas when assembled directly to the Base Station. This will “detune” the antennas which can result in noise or loss of RF signal at the Base Station, see Figure 5-8.

2. Placing the BTR on top of a shelf or equipment rack unobstructed without remoting the antennas is OK.

1. Placing BTRs in a shelf or equipment rack and using remote antennas is OK.

3. Placing BTRs in a shelf or equipment rack with the antennas mounted on the back of the BTR or the side of the rack is **BAD**.

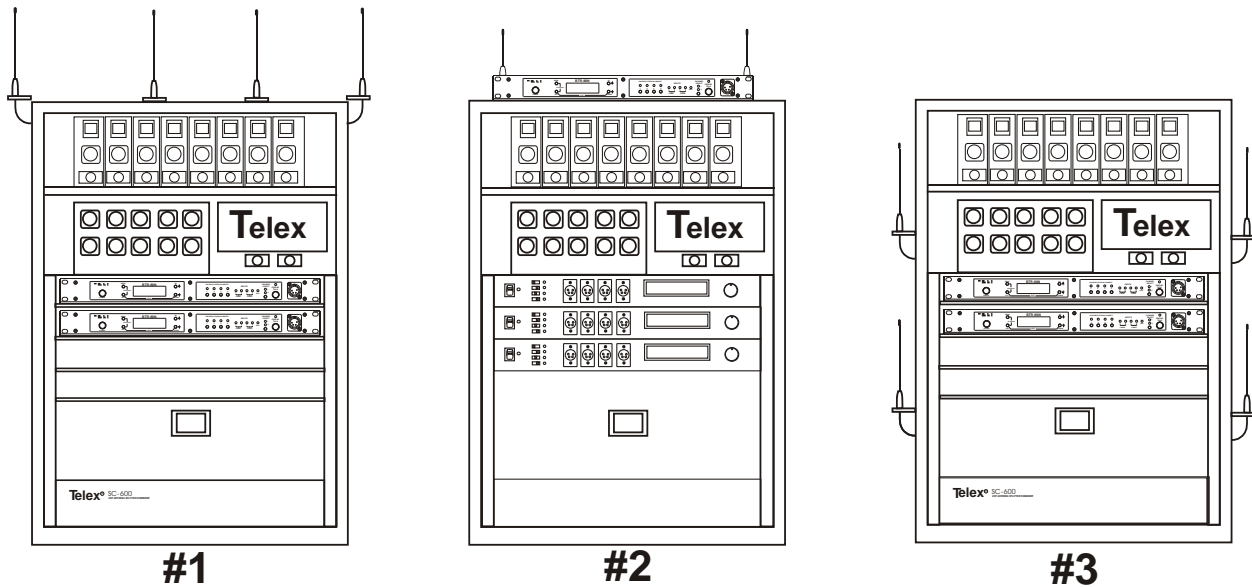


Figure 5-8  
Antenna Placement

## Improving Reception and Increasing Range

Keeping the distance from the base station and beltback as short, and unobstructed as possible will produce the most reliable performance.

The base station is supplied with two antennas. This should provide satisfactory system performance in most applications. System range can be enhanced by remotely mounting the 1/2-wave antennas. The 1/2 wave antennas are ground plane independent, so a ground plane is not required for good performance.



## BTR-80N Operation

This Section will discuss the operation and features of the BTR-80N base station. The section will open with the base operation and quick system setup of a BTR-80N system. It will then discuss basic interfacing and setup of a base station. Finally it will end with the connection of multiple base stations and discussion of the links between them.

### Basic Operational Description

The BTR-80N narrow band wireless intercom system offers the most comprehensive, user friendly and versatile set of features available in wireless intercom systems anywhere in the world.

The base station can accommodate up to 4 full duplex TR-80N or TR-82N beltacks. A base may be used with an unlimited number of beltacks in push-to-TX (half duplex) operation. In push-to-TX mode the unit provides a "First-On-Latch-Out" feature. This feature allows only one beltack transmitter active at a time when multiple users are on a single base receive channel.

The base station, via the beltacks or it's local headset, allows communication with other wireless or wired users. The 2-wire and 4-wire intercoms may even be used at the same time. The wired audio interfaces to the base are:

- 2-Wire (Telex, RTS, Clear-Com) - 2 intercom channels
- 4-Wire - 2 audio channels
- Auxiliary (both input and output)
- SA (Stage Announce) (output)
- WTA (Wireless Talk Around). 2 channels of a private 2-wire intercom just among TR-80N and TR-82N beltacks.
- Local base station headset

The base also has a relay closure available that is activated when the SA is pressed at any beltack. There are 4 easily accessible portable connect buttons on the front panel. The buttons may be used to turn off the audio from any of the four base receivers while at the same time killing the talk/transmitter at the associated beltack.

The base station comes with 36 engineering selected, intermodulation-avoiding groups of channels, plus the ability

for the user to enter frequencies of their own via 12 user defined groups.

### System Quick Start

The following is a list to quickly get a base station and beltacks operating.

1. Unpack the base and connect the power cord and antennas.
2. Connect base to audio interfaces. For example; 2-wire, 4-wire, SA, Auxiliary local headset.
3. Press and hold [MENU] as powering-up the base station. Release button when base station displays "...FACTORY SETUP...".
4. Press [MENU] as powering-up the beltacks(s)
5. Use the [UP] and [DOWN] arrow button to change the channel to an unoccupied receive channel on the base station. Then press [SET] twice to set channel and group.
6. The base should now display the audio channel of the beltack and a battery symbol will appear shortly.
7. Plug a headset into each beltack. Adjust the software menu for microphone gain so the overmodulation light flashes only on some of the words at normal speech levels.



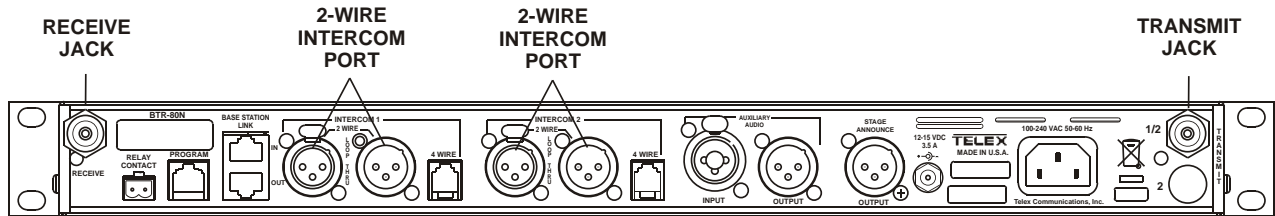


Figure 6-1  
BTR-80N Rear View

## Transmit and Receive Antennas

The TNC transmit jack and receiver jack are both labeled on the rear of the unit. The base station will come with two 1/2 wave antennas. Always match the color dot on the rear panel of the base station with the colored band on the antenna.

## 2-Wire Intercom Ports

The base station has the ability to interface to two, 2-wire external audio intercom systems. These XLR jacks are designated intercom 1 and 2 on the rear panel.

They accept Telex, RTS and Clear-Com types of intercom systems. The pinouts of these standard types of intercom are shown in Figure 6-2.

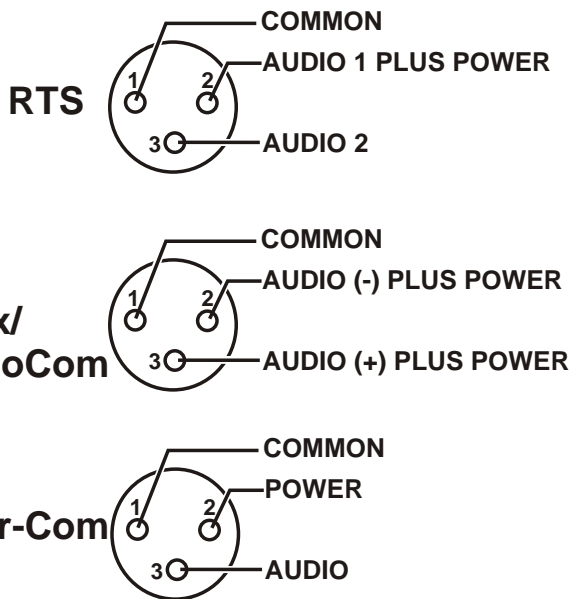


Figure 6-2  
Pin Outs of RTS, Telex and Clear-Com Intercoms

The base station does not require "wet" intercom lines for operation. Wet intercom lines are those with D.C. voltages on them for powering 2-wire devices. The base will loop thru wet intercom lines with currents up to 2 Amps.

**Warning! Do not loop thru more than 2 Amps of current. Damage to the base station may result.**

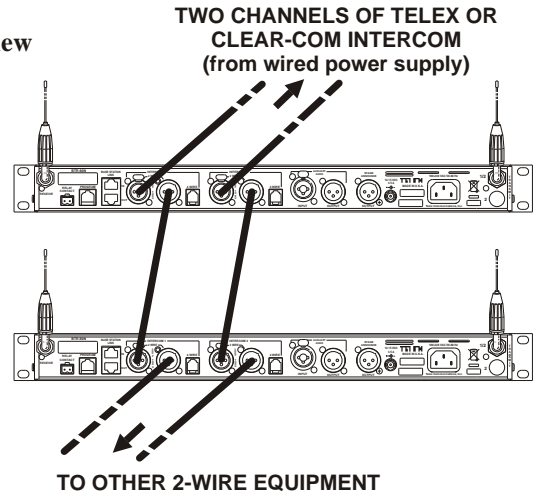


Figure 6-3  
Loop-thru of Two Base Stations connected with Telex/Audiocom or Clear-Com Intercoms

Since RTS-TW carries both channels of audio on one cable, the four intercom XLR connectors are connected in parallel when RTS is selected. Thus any one of the four intercom XLRs may be used for RTS input. As shown in Figure 6-4, looping thru of the audio may also be accomplished via any of the rear panel XLRs when in RTS mode. For a description of how to set up the 2-wire ports refer to "Intercom Settings" in this section.

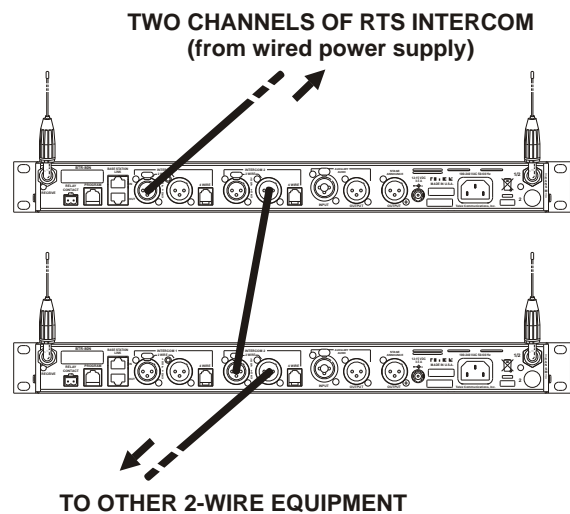
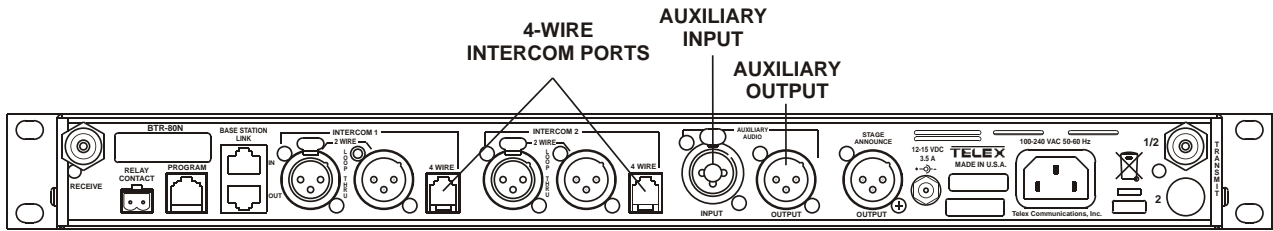


Figure 6-4  
Loop-thru of Two Base Stations Connected with RTS Intercoms

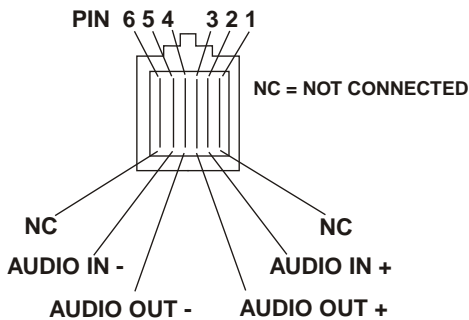
The 2-wire intercom may be used at the same time as the 4-wire intercom.



**Figure 6-5**  
**BTR-80N Rear View**

## 4-Wire Intercom Ports

The BTR-80N can connect to two 4-wire audio intercom systems. These 6-pin modular jacks (RJ-11) are designated "4 wire" under intercom 1 and 2 titles on the rear panel. (See Figure 6-5). The jacks' pinout is shown in Figure 6-6.

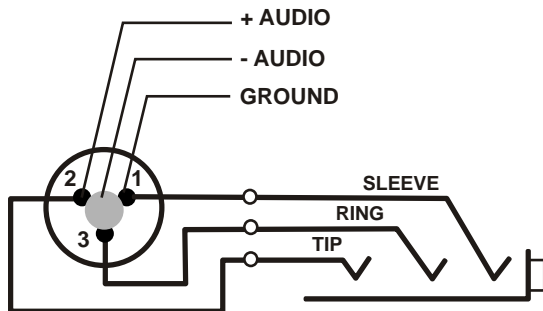


**Figure 6-6**  
**Pinout of the 4-Wire Jack**

The 4-wire intercom may be used at the same time as the 2-wire intercom.

## Auxiliary Input/Output

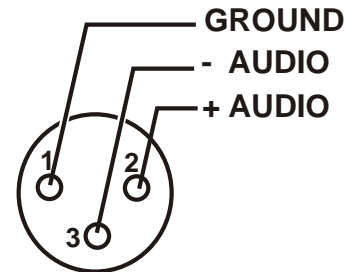
The auxiliary input jack is a combination jack. It will accept either a 3-pin XLR or 1/4" (6.3mm) plug, the expected input is a balanced line level input. The XLR plug and 1/4 plug are



wired in parallel as shown in Figure 6-7.

**Figure 6-7**  
**Auxiliary Input XLR and 6.3 mm Jack Pinouts**

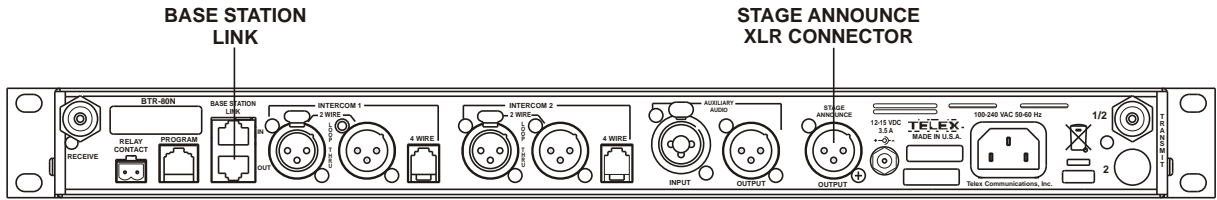
Auxiliary output is a 3-pin XLR jack. It produces a line level balanced output. Please refer to Figure 6-8 for the pin out.



**Figure 6-8**  
**Pinout of the Auxiliary Output Jack**

The auxiliary input/output can be set to local, global or off. (See the Aux Settings menu in the base). The output level is settable in software.

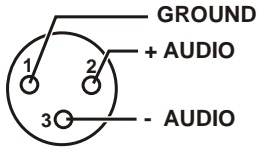
- **Local Aux Input** = The input audio is only heard at the base station's local headset and beltpacks.
- **Local Aux Output** = The output audio is only from the local headset and beltpacks.
- **Global Aux Input** = The input audio is heard at the base station's local headset, beltpacks and placed on the 2-wire/ 4-wire intercom.
- **Global Aux Output** = The output audio is from the base station's local headset, beltpacks and 2-wire/4-wire intercom.
- **Off** = The auxiliary input and output is off.



**Figure 6-9**  
**BTR-80N Rear View**

## Stage Announce (SA) / Relay

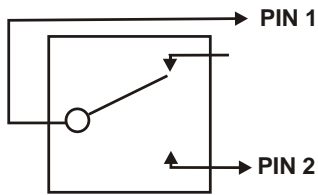
The stage announce 3-pin XLR connector (see Figure 6-9) is where audio exits the base from the beltpack that has pressed the [SA] button. The pinout of the plug connector is shown in Figure 6-10.



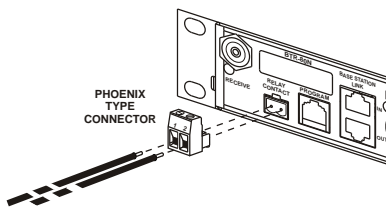
**Figure 6-10**  
**Stage Announce Pinouts**

The stage announce output is balanced audio at line level. The output level is settable in software.

A relay contact closure is also activated when an beltpack user presses the [SA] button. The contacts are normally open (N.O.). The relay schematic may be seen in Figure 6-11. The rating of the relay is 1 Amp at 24 Volts AC or DC maximum.



**Figure 6-11**  
**Relay Output Schematic (Normally Open)**

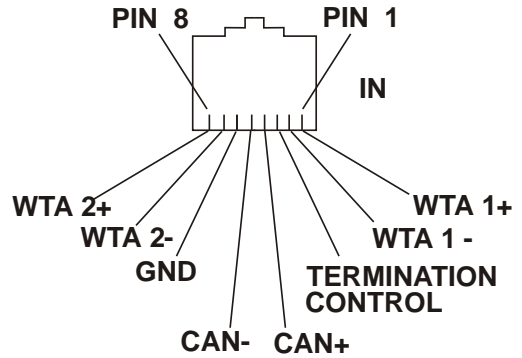


**Figure 6-12**  
**Screw Terminal Adapter**

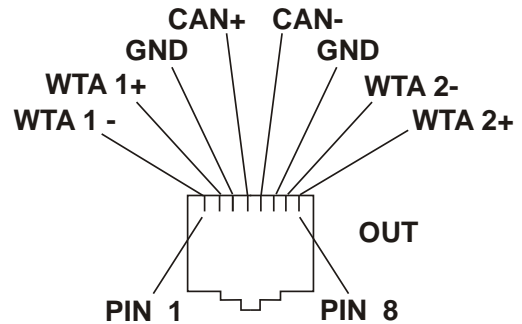
A **Phoenix** type connector (supplied) plugs into the relay contact port on the rear of the base station. This connector provides a screw-type closure for an easy connection to wires. Please see Figure 6-12.

## Base Station Link

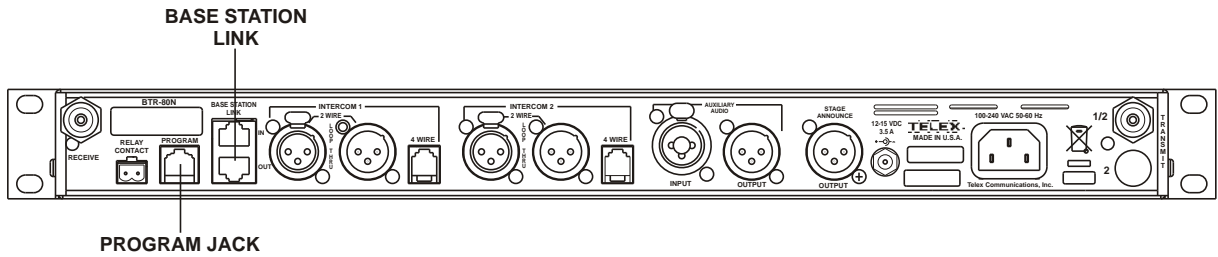
This pair of RJ-45 jacks allow the passage of wireless talk around audio (WTA), WTA termination control voltage and CAN bus data between multiple base stations. Up to 8 base station may be connected with the base station link. If just using WTA between bases, up to 16 base stations may be connected together. The pinout of the IN jack and OUT jack may be seen in Figures 6-13 and 6-14 respectively.



**Figure 6-13**  
**Base Station Link IN RJ-45 Jack Pinout**



**Figure 6-14**  
**Base Station Link OUT RJ-45 Jack Pinout**



**Figure 6-15**  
**BTR-80N Base Station Link Jack and Program Jack**

## Base Station Link Jack

WTA 1 and WTA 2 audios in the BTR-80N are two independent 2-wire intercom channels. Up to 16 base stations may be connected together to share WTA audio. Do not confuse WTA audio with CAN bus data as only 8 base stations may be connected together to share CAN bus data. Not only does the WTA Link cable pass both channels of WTA audio, it passes a logic level so the 1st base station in the chain is the only one that provides a termination of the WTA intercom channels. Care must be taken to connect cables between base stations from the OUT of base one to the IN of base two and so forth. If the WTA link cable is passed from OUT to OUT or IN to IN the WTA audio may be terminated in multiple places and causing the WTA audio level to be greatly reduced.

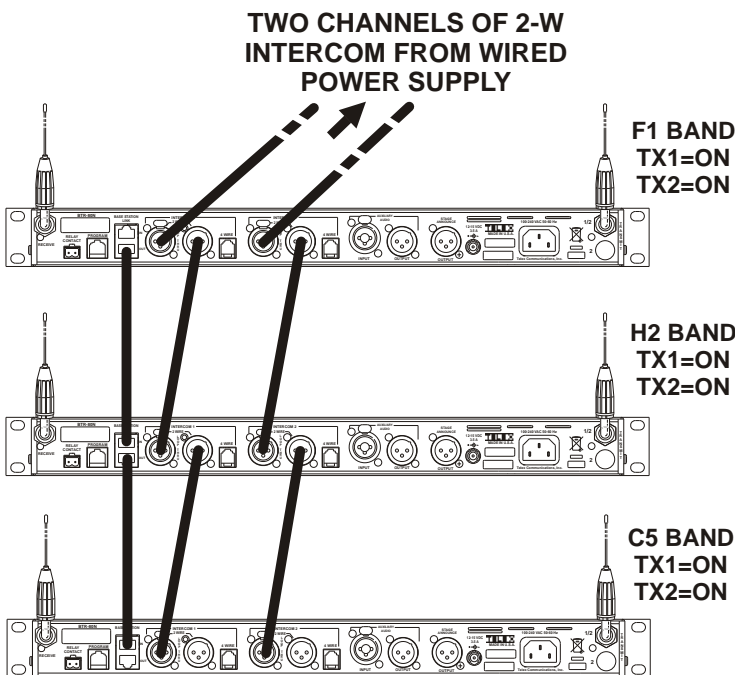
The base station link jacks can interface with other base stations via two different types of cables:

- Base Link Cable (BLC)
  - Straight thru cable that passes CAN data, WTA audio and WTA termination signal.
- CAN Bus Termination Cable (CTC)
  - Cable that passed WTA audio and WTA termination signal but does NOT pass CAN data. Acts as a termination of the CAN networks on either side of it.

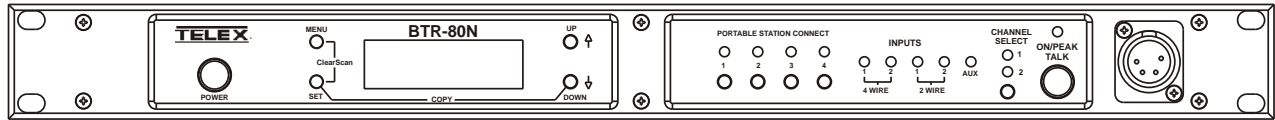
Detailed information on the pinout and operation of these cables may be found under, "Connection of Multiple Base Stations with Link Cables" later in this section.

## Program Jack

This jack is only used for updating the internal software of the base station. It is typically used only by the manufacturer and service centers.



**Figure 6-16**  
**Multiple base Stations Connected via 2-Wire Cables and Sharing WTA Audio Only**



**Figure 6-17**  
**Front View - BTR-80N**

## Powering the Base Station

The base station may be powered two different ways:

- Line power at the IEC receptacle. Accepts 100 - 240 VAC, 50 or 60 Hz.
- 12 - 15 VDC Power. Accepts a 5.5 mm by 2.5 mm screw on plug. Source must supply at least 3.5 Amps.

Power the base station via a press of the push button located to the far left as facing the base station.

Turn off the base station by pressing and holding the power button down for 1 second.

Both line power and DC power may be connected to the base station at the same time. If AC line voltage drops the base will draw power from the DC input automatically. When the AC line power is restored to the base the base will again automatically switch back to AC power. There will be no interruption of base operation during these transitions.

**Warning!:** Do not power-up a base station within 3 seconds of unit being turned off. Voltages within the unit need time to drop below a threshold. If powered-up within the above time, the unit may boot as the wrong frequency band.

## Start-up Screen

When the BTR-80N is powered-up the 1st screen displayed is the start-up splash screen. It will be displayed for about 3 seconds. This screen contains both the software version number and band of the base. The following screen has software version sb4010C and indicates it is a F1 band unit.



**Start-up Screen**

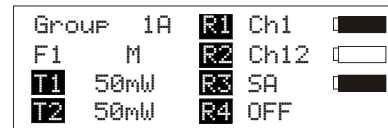
After 3 seconds the status screen will appear.

**NOTE:** A complete screen flowchart of the base station is available in section 8 of this manual.

## Status Screen

The status screen is the main information screen of the base station. It displays a number of system items:

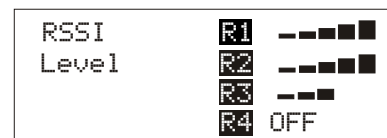
- Frequency group of the base station
- Band of base station
- Mode of base station (Master or Servant)
- Transmitter 1 power setting
- Transmitter 2 power setting
- The beltpack's current activity
- Battery life of the beltpack(s)
- The status of the base's receivers



**Status Screen**

## RSSI Screen

RSSI stands for Received Signal Strength Indicator. This screen displays the detected signal strength on each of the four receivers in the base.



The following are the approximate receive levels indicated by the bars after each receiver.

- OFF = Receiver is deselected via the front panel
- 0 bar < 0.2 uV
- 1 bar ~ 0.6 uV
- 2 bars ~ 2 uV
- 3 bars ~ 6 uV
- 4 bars ~ 10 uV
- 5 bars > 20 uV

If no beltpacks are operating, an RSSI level of two bars or above can indicate interference on that frequency. A different receive channel should be selected for that receiver.

### RSSI Screen:

1. From the status screen press and hold [MENU] for two seconds.
2. To exit the RSSI screen press [MENU] to arrive back at the status screen.

## Group/Channel Selection

The group/channel, group/frequency and frequency edit screens allows the user to set the frequencies of the base station. Each screen has a slightly different way of frequency selection.

GROUP	1A	R1	Ch	01
T1	50mw	2	Ch	02
2	50mw	3	Ch	03
		4	Ch	04

**Group/Channel Screen**

### Group/Channel Select

This screen displays the group number and the channel assigned to each of the four receivers. Each channel is a unique base receive frequency. The frequencies of factory-defined groups, groups 1A to 18, can only be selected from a set number of predetermined channels. User-defined groups 18u to 30u may be changed by the user to any frequency within range of the base.

Group/Channel Screen:

1. From the status screen press [MENU].
2. The main selection screen will indicate four options;
  - a. GP\_CH select
  - b. Base Main
  - c. Intercom Settings
  - d. Aux Settings
3. Use the [UP]/[DOWN] arrow buttons and move the arrow to GP\_CH Select. Now hit [SET].
4. This is the Group/Channel Select screen. This Group will be flashing. Use the [UP]/[DOWN] arrow buttons to select a different group, then hit [SET] to accept the change.
5. The receiver 1 channel will begin to flash. Use the [UP]/[DOWN] arrow buttons to select a channel, then hit [SET] to accept the change and move to the next receiver. After the last receive channel is set the unit will change to the group and channels selected. Then the unit will return to the main selection screen.

### Group/Frequency Select

This screen displays the group number and frequencies assigned to each of the four receivers. It is just like the Group/Channel screen except the receive channels are displayed as frequencies. Also the transmit frequencies are now displayed.

GROUP	1A	R1	614.125
		2	614.450
T1	482.225	3	617.675
2	485.525	4	618.425

**Group/Frequencies Screen**

Group/Frequencies Screen:

1. From the status screen press [MENU].
2. The main selection screen will indicate four options;
  - a. GP\_CH select
  - b. Base Main
  - c. Intercom Settings
  - d. Aux Settings
3. Use the [UP]/[DOWN] arrow buttons and move the arrow to GP\_CH Select. Now hit [SET].
4. Press [MENU] again in the Group/Channel Screen.
5. This is the Group/Frequency Select screen. This Group will be flashing. Use the [UP]/[DOWN] arrow buttons to select a different group, then hit [SET] to accept the change.
6. The receiver 1 frequency will begin to flash. Use the [UP]/[DOWN] arrow buttons to select a frequency, then hit [SET] to accept the change and move to the next receiver. After the last receive frequency is set the unit will change to the group and frequencies selected. Then the unit will return to the main selection screen.

### Frequency Edit (User-Defined Groups Only)

This screen is similar to the Group/Frequency select screen but allows the complete editing of each transmit and receive frequency.

Group	25u	Ch1	614.100
Freq Edit		2	614.250
T1	482.300	3	615.350
2	485.650	4	618.950

**Frequency Edit**

Frequency Edit Screen:

1. From the status screen press [MENU].
2. The main selection screen will indicate four options;
  - a. GP\_CH select
  - b. Base Main
  - c. Intercom Settings
  - d. Aux Settings
3. Use the [UP]/[DOWN] arrow buttons and move the arrow to GP\_CH Select. Now hit [SET].
4. Press [MENU] two more times
5. This is the Frequency Edit screen. The Group will be flashing. Use the [UP]/[DOWN] arrow buttons to select a different group, then hit [SET] to accept the change.
6. The transmitter 1 frequency will begin to flash. Use the [UP]/[DOWN] arrow buttons to select a frequency, then hit [SET] to accept the change and move to the next transmitter. After transmitter 2 is set the channel 1 receiver frequency will begin to flash.
7. Use the [UP]/[DOWN] arrow buttons to select a frequency, then hit [SET] to accept the change and move to the next channel. After the last receive channel frequency is set the unit will set itself to the frequencies and return to the main selection screen. Press [MENU] at any time and the unit will change to the group and frequencies selected.



## Base Main Settings

Settings contained in the base main menu are the following:

- Local headset microphone gain
- Local headset volume
- Transmit power level
- Squelch setting for each receiver
- Stage Announce (SA) audio level setting
- Receive antenna bias T power
- Base Number...Master or Servant

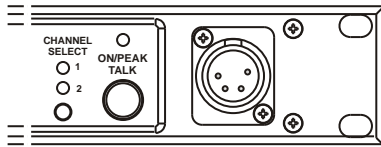


Figure 6-18 Local Headset Area of Front Panel

### Talk Button

Press the front panel talk button to enable the audio path from the headset microphone. The talk light will activate when the talk button is active. This light has two functions.

Green indicates activation of the talk button.

Red or flashing red on most speech indicates too strong of input audio (Peak).

Peak Light	Microphone Gain
Light flashes on loudest speech	Okay
Light flashes on all speech	Too high
Light never flashes on norm speech	Too low

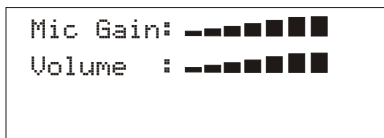
Table 6-1 Peak Light and Microphone Gain

### Channel Select Button

Press this button to select the intercom channel for the local headset. Each press of the button will cycle through the options; intercom one, intercom two, both and then back to intercom one. The LEDs above the button will indicate what channel is currently connected to the local headset.

### Local Headset Volume and Gain

The local headset volume and microphone gain are set in the following software screen.



Microphone Gain/Volume

The microphone gain and volume level settings are in the following location:

1. From the status screen press [MENU].
2. Use the [UP]/[DOWN] arrow buttons and move the arrow to Base Main. Now hit [SET].
3. Use the [UP]/[DOWN] arrow buttons and move the arrow to Local Headset. Now hit [SET]/
4. The microphone gain will be flashing. Use the [UP]/[DOWN] arrow button to adjust the gain. Each press of the button is about 3 dB step increase or decrease of gain. Press [SET] when finished.
5. The volume will be flashing. Use the [UP]/ [DOWN] arrow button to adjust the volume. Each press of the button is about a 3 dB step increase or decrease of volume. Press [SET] when finished.
6. The base main selection menu screen will be shown. Press [MENU] twice to go back to the status screen. The base will default back to the status screen in 5 minutes if no action is taken.

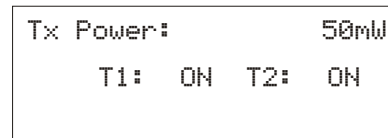
### Base Transmit Power

The base station has the following possible transmit power settings that apply to both transmitters:

- Off
- 10mW
- 50mW (Default)
- 100mW
- 249mW

The user may also set which transmitter is on or off.

The default is both transmitters on.



### TX Power

These transmit power settings are in the following location:

1. From the status screen press [MENU].
2. Use the [UP]/[DOWN] arrow buttons and move the arrow to Base Main. Now hit [SET].
3. Use the [UP]/[DOWN] arrow buttons and move the arrow to Tx- Power. Now press [SET].
4. The transmit power level will be flashing. Use the [UP]/[DOWN] arrow button to adjust the level. Press [SET] when finished.
5. The transmitters on/off will now be flashing. Use the [UP]/[DOWN] arrow button to set the option. Press [SET] when finished.
6. The base main selection menu screen will be shown. Press [MENU] twice to go back to the status screen. The base will default back to the status screen in 5 minutes if no action is taken.

## Squelch Settings

Each of the four receivers of the base station has four settable levels for squelch. These levels are approximately equivalent to a SINAD level to open squelch for a receiver. Basically, the higher the squelch level number is the quieter the receiver will be before it squelches, however the RF range will be slightly less than a receiver with a lower number.

- 00 = OPEN (For testing only, Do not use)
- 01 = 12 dB SINAD
- 02 = 20 dB SINAD (Default)
- 03 = 24 dB SINAD

### WARNING!

#### DO NOT USE SQUELCH SETTING 00.

A squelch level of 00 will turn off all squelch gating. This can allow loud white noise into the audio of a base station if no transmitter is on that RF frequency or the portable select button is on. This setting is for test purposes only.

```
Squelch   R1 02
Level     R2 02
          R3 02
          R4 02
```

#### Squelch Setting

The squelch settings are in the following location:

1. From the status screen press [MENU].
2. Use the [UP]/[DOWN] arrow buttons and move the arrow to Base Main. Now press [SET].
3. Use the [UP]/[DOWN] arrow buttons and move the arrow to Squelch Settings. Now press [SET].
4. The receiver 1 squelch setting will be flashing. Use the [UP]/[DOWN] arrow button to adjust the setting. Press [SET] when finished. Set the other three receivers the same way.
5. After the last receiver is set, the base main selection menu screen will be shown. Press [MENU] twice to go back to the status screen. The base will default back to the status screen in 5 minutes if no action is taken.

Squelch Note: The base employs two different types of squelches. A fast acting noise type squelch and a slower data squelch. For audio to be received by the base both a good signal-to-noise audio signal (with a noise threshold set via the usersquelch settings above) and a valid data stream must be detected.

### Stage Announce Level

The software option will allow the user to adjust the audio output level of the rear panel stage announce (SA) jack.

```
SA Level   : ██████████
Antenna Pwr: Off
Base No    : 01 Master
```

The stage announce level is in the following menu path:

1. From the status screen press [MENU].
2. Use the [UP]/[DOWN] arrow buttons and move the arrow to Base Main. Now press [SET].
3. Use the [UP]/[DOWN] arrow buttons and move the arrow to More...Now press [DOWN] again.
4. The stage announce (SA) level will be flashing. Use the [UP]/[DOWN] arrow button to adjust the setting. Each press of the button is about a 6 dB step increase or decrease of volume. Press [SET] when finished.
5. Step through the other setting in the screen by pressing [SET]. After the last option on the screen the display will return to the base main selection menu. Press [MENU] twice to go back to the status screen. The base will default back to the status screen in 5 minutes if no action is taken.

### Antenna Power

Antenna power may be set On or Off. If antenna power is on 9VDC is placed on the center pin of the receive antenna. The purpose of this Voltage is to power in-line low noise amplifiers on the receive coaxial cable in order to compensate for excessive RF signal loss due to long cable runs. The default is off.

Specifications of the power on the antenna jack:

Options: On/Off (Off = Default)

Voltage: 9 VDC

Current: 100mA Max.

Protection: Current limited to 100mA.

Base can withstand a continuous short to ground without damage.

```
SA Level   : ██████████
Antenna Pwr: Off
Base No    : 01 Master
```

#### Antenna Power

The antenna power is in the following area of the software menus:

1. From the status screen press [MENU].
2. Use the [UP]/[DOWN] arrow buttons and move the arrow to Base Main. Now press [SET].
3. Use the [UP]/[DOWN] arrow buttons and move the arrow to more.... Now press [DOWN] again.
4. The stage announce (SA) level will be flashing. Press [SET] to arrive at the Antenna Power option flashing. Use the [UP]/[DOWN] arrow button to adjust the setting. Press [SET] when finished.
5. Step through next setting in the screen by pressing [SET]. The display will return to the base main selection menu. Press [MENU] twice to go back to the status screen. The base will default back to the status screen in 5 minutes if no action is taken.



## CAN Bus Number

The CAN bus number for a base station must be set only in multiple base station configurations and only if the operator wishes to have the following features shared among multiple base stations.

- First - On - Latch - Out of receiver channels (Push-to-transmit mode).
- Automatic beltpack TX power control.
- Automatic beltpack user ID assignment.
- Beltpack TX and Talk shutdown via the base front panel.

The valid base number settings are listed in Table 6-2. Please see "Connection of Multiple Base Station with Link Cables" within Section 6 for more information.

Base Number	Function
01	Master
02	Servant
03	Servant
04	Servant
05	Servant
06	Servant
07	Servant
08	Servant
09	Unassigned (Default)

**Table 6-2**  
**Valid Base Number Settings**

```
SA Level   : ████████
Antenna Pwr: Off
Base No   : 01 Master
```

### Base Number

1. From the status screen press [MENU].
2. Use the [UP]/[DOWN] arrow buttons and move the arrow to Base Main. Now press [SET].
3. Use the [UP]/[DOWN] arrow buttons and move the arrow to More...Now press [DOWN] again.
4. Press [SET] until you arrive at the Base Number option flashing. Use the [UP]/[DOWN] arrow button to set the number. Press [SET] when finished.
5. The display will return to the base main selection menu. Press [MENU] twice to go back to the status screen. The base will default back to the status screen in 5 minutes if no action is taken.

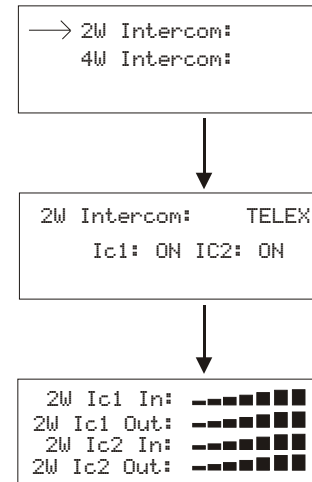
## Intercom Settings

There are multiple parameters to set in the Intercom Setting menu:

- 2-wire intercom type: Telex, RTS, Clear-Com, Off.
- Only intercom 1 active, only intercom 2 active, both active, both off.
- 2-wire intercom input/output levels
- 4-wire intercom on/off.
- 4-wire intercom input/output levels

### 2-wire Intercom

The screens below show the progression of setting 2-wire parameters.



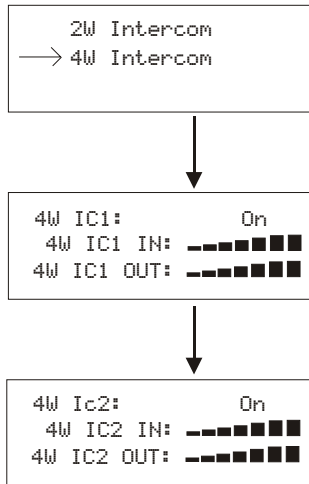
### 2-Wire Intercom

The 2-wire intercom settings are in the following area of the software menus:

1. From the status screen press [MENU].
2. Use the [UP]/[DOWN] arrow buttons and move the arrow to Intercom Settings. Now press [SET].
3. Use the [UP]/[DOWN] arrow buttons and move the arrow to 2-W. Now press [SET].
4. The two 2-wire intercom type will be flashing. Use the [UP]/[DOWN] arrow buttons to set the intercom type. Press [SET] when finished. If off is selected the user will be placed back at the 2-W/4-W selection menu.
5. The intercom channel will be flashing. Use the [UP]/[DOWN] arrow buttons to set the intercom 1 only, intercom 2 only or both. Press [SET] when finished.
6. The intercom input level will be flashing. Use the [UP]/[DOWN] arrow buttons to set the input level. Press [SET] when finished. Proceed through the intercom setting in a similar manner.
7. After the last level on the screen the display will return to the 2-W/4-W selection menu. Press [MENU] twice to go back to the status screen. The base will default back to the status screen in 5 minutes if no action is taken.

## 4-Wire Intercom

The screens below show the progression of setting 4-wire parameters.



The 4-wire intercom settings are in the following area of the software menus:

1. From the status screen press [MENU].
2. Use the [UP]/[DOWN] arrow buttons and move the arrow to Intercom Settings. Now press [SET].
3. Use the [UP]/[DOWN] arrow buttons and move the arrow to 4W. Now press [SET].
4. The intercom one 4-wire on/off selection will be flashing. Use the [UP]/[DOWN] arrow buttons to set it on or off. Press [SET] when finished. If off is selected the user will skip to the intercom two screen..
5. The intercom input level will be flashing. Use the [UP]/[DOWN] arrow buttons to set the input level. Press [SET] when finished. Proceed through the intercom output settings in a similar manner.
6. Now the intercom two 4-wire on/off selection will be flashing. Use the [UP]/[DOWN] arrow buttons to set it on or off. Press [SET] when finished. If off is selected the user will skip to the 2W/4W selection screen
7. The intercom input level will be flashing. Use the [UP]/[DOWN] arrow buttons to set the input level. Press [SET] when finished. Proceed through the intercom output settings in a similar manner.
8. After the last level on the screen the display will return to the 2W/4W selection menu. Press [MENU] twice to go back to the status screen. The base will default back to the status screen in 5 minutes if no action is taken.

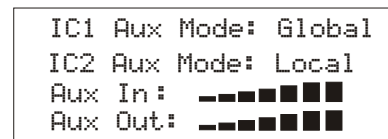
## Auxiliary Settings

The parameters to set in the auxiliary setting menu are the following:

- Intercom 1 Auxiliary mode: Local, Global or Off.
- Intercom 2 Auxiliary mode: Local, Global or Off.
- Auxiliary input/output levels.

The auxiliary setting for Local, Global and Off are defined as the follows:

- Local = Any audio placed into the auxiliary input port is routed only to the base's local headset and beltpack(s). Any audio heard out of the auxiliary output port is only from the base's local headset and beltpacks(s).
- Global = Any audio placed into the auxiliary input port is routed not only to the base's local headset and beltpack, but also to any wired 2-wire or 4-wire system connected to the base station. Any audio heard from the auxiliary output is not only from the base's local headset and beltpack, but also from any wired 2-wire or 4-wire system connected to the base station.
- Off = The auxiliary input and output for the intercom channel is disabled.



The auxiliary settings are in the following area of the software menus:

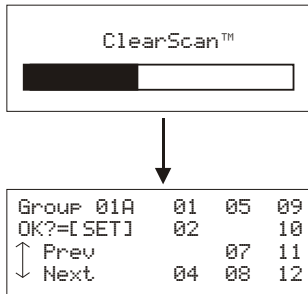
1. From the status screen press [MENU].
2. Use the [UP]/[DOWN] arrow buttons and move the arrow to Aux Settings. Now press [SET].
3. The intercom one auxiliary local, global or off selection will be flashing. Use the [UP]/[DOWN] arrow buttons to select the option. Press [SET] when finished. Proceed through intercom two in a similar manner.
4. The auxiliary input level will be flashing. This level applied to both intercom channels. Use the [UP]/[DOWN] arrow buttons to set the input level. Press [SET] when finished.
5. The auxiliary output level will now be flashing. This level applies to both intercom channels. Use the [UP]/[DOWN] arrow buttons to set the output level. Press [SET] when finished.
6. After the last level on the screen the display will return to the main selection menu. Press [MENU] twice to go back to the status screen. The base will default back to the status screen in 5 minutes if no action taken.

### ClearScan™

When ClearScan™ is activated the base will shut down its transmitters and begin scanning receive frequencies. The frequencies it scans are those in its factory-defined groups and any user-defined groups that have at least one frequency defined. The result is a screen like that shown in Figure 6-19. The first group shown will be the one with the most clear receive channels. Using the arrow buttons, the next group down is the one with next most clear frequencies and so forth.

*Key Sequence:* Press and hold [MENU] + [SET] for three seconds to start ClearScan™.

The process may take up to 12 seconds to complete. It depends on how many user-defined groups are set-up. The more groups the longer the scan will take.



**ClearScan™ Results Screen**

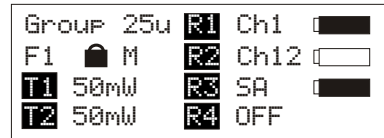
The base will not be set to the displayed ClearScan™ result if the user presses the [MENU] button to bail out.

### Lockout

This function locks out a user from changing any options at the base station except local headset microphone gain and volume.

*Key Sequence:* Press and hold the [UP] + [DOWN] buttons for 2 seconds to lock or unlock the base station.

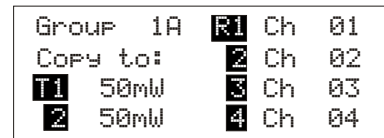
A padlock will appear on the status screen if the base is locked.



**Status Screen with Lockout Active**

### Copy

Press and hold the [SET] + [DOWN] buttons for 2 seconds only in the group/channel select screen and the following screen will appear:



This allows the user to select a factory defined group and copy it to a user-programmed group. Now the user could edit that group slightly if desired.

### 1st Use Defaults

This function sets the base station to Group 01A, channels 1, 2, 3, 4 and RETAINS any user-defined groups in memory. It will set the unit to factory defined parameters.

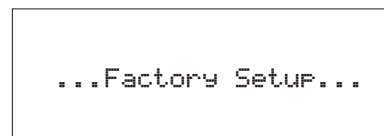
*Key Sequence:* Press and hold [MENU] while turning on the base station. Release button after "...Factory Setup..." is displayed

### Factory Defaults

This function sets the base station to Group 01A, channels 1, 2, 3, 4, and ERASES any user defined groups in memory. It will set the unit to factory defined parameters.

*Key Sequence:* Press and hold [MENU] + [SET] + [UP] + [DOWN] for 2 seconds.

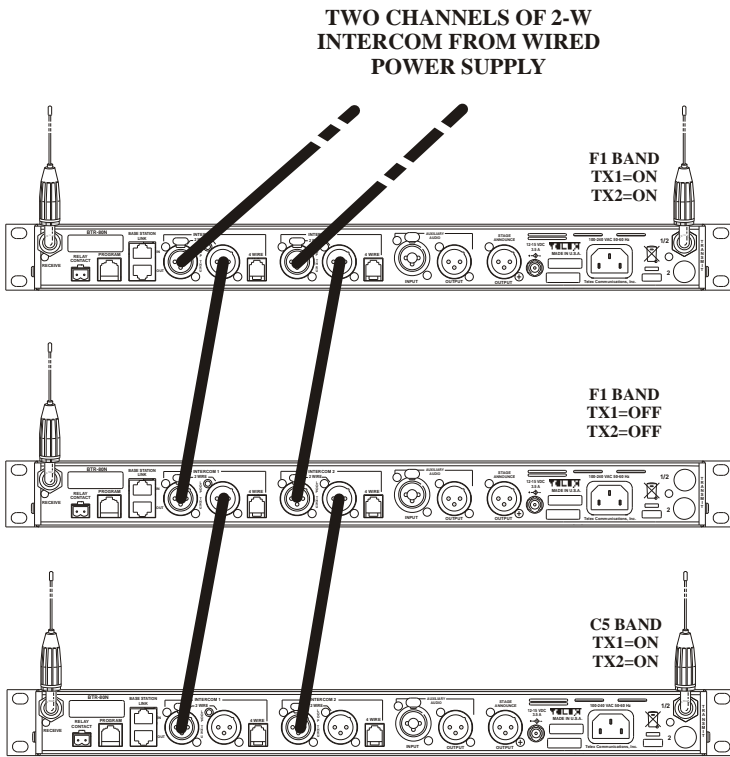
The following screen will be flashed before the unit reboots.



**Factory Defaults**

## Connection of Multiple Base Stations with the Link Cables

This section discusses various configurations of multiple base stations using link cables. Multiple base stations may be connected via standard 2-wire and 4-wire intercoms without additional link cables between them. They will still transmit and receive intercom 1 and 2 audio normally from the beltpacks.



**Figure 6-19**

**Multiple base stations with only 2-wire intercom channels 1 and 2 connected between them.**

However by connecting multiple bases together via link cables, in addition to any 2-wire or 4-wire audio connections in use, the feature set of a single base becomes available to the whole system. This feature set also includes base stations that have their transmitters off in order to conserve RF spectrum.

These features are:

- Wireless talk around (WTA) channels 1 and 2 shared between base stations.
- First-On-Latch-Out of beltpacks extended to base stations with their TXs off (when beltpack(s) are in push-to-transmit mode).
- Automatic beltpack TX power control extended to base stations with their TXs off.
- Automatic beltpack user ID assignment extending to base stations with their TXs off.

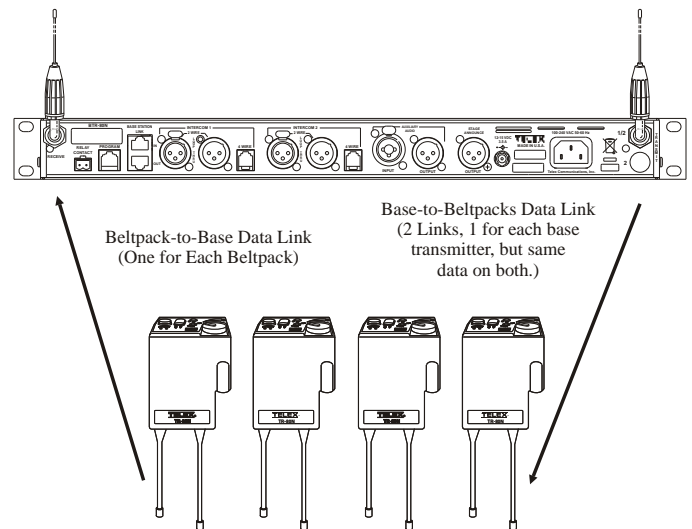
- Beltpack TX and Talk shutdown via the base front panel extended to base stations with their TXs off (when beltpack(s) are in push-to-transmit mode).
- Beltpack TX and Talk shutdown via the base front panel extended to base stations with their TXs off (when beltpack(s) are in push-to-transmit mode).
- Beltpack Talk shutdown via the base front panel extended to base stations with their TXs off (when beltpack(s) are in push-to-talk mode).

Before the configurations are presented, a discussing on RF data links plus master and servant base stations will be helpful in understanding the multiple base arrangements.

## Over-the-Air Data Links

There are two RF data communication links within a BTR-80N system.

- Beltpack-to-base conveys:
  - Current button(s) selected
  - Battery level
  - Beltpack ID set confirmation
- Base-to-beltpack conveys:
  - Beltpack user ID
  - Beltpack TX power level
  - Beltpack TX and/or Talk shutdown
  - First-On-Latch-Out



**Figure 6-20**

**Base-to-Beltpack and Beltpack-to-Base RF Data Links.**

These two data paths are intact when there is only one base communicating to beltacks. They are also intact when many base stations on different TX and RX frequencies are communicating to their beltacks. However in a system with one or more base stations with their transmitters off, the base-to-beltack data link is lost for these beltacks.

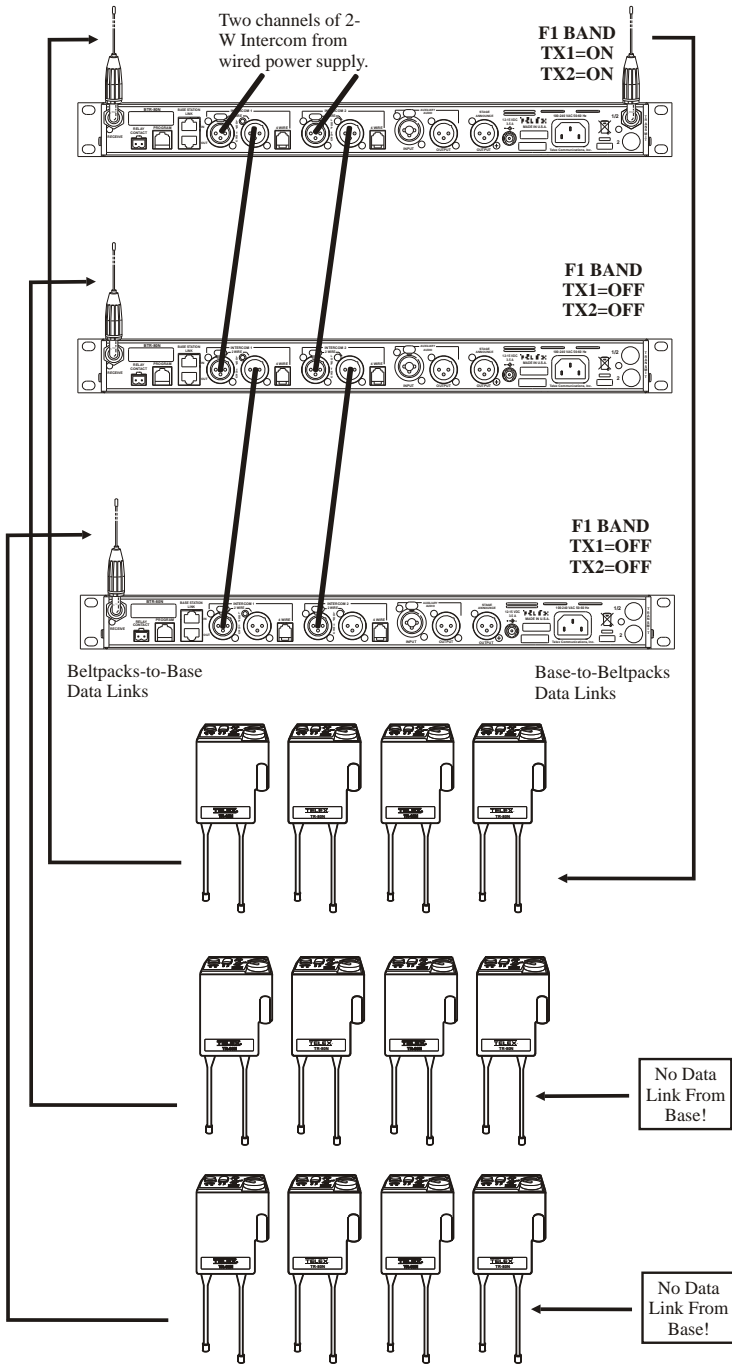


Figure 6-21

Three base stations connected via 2-wire intercom only. Two bases have their transmitter off; one has its transmitters on.

A wired data link is needed to communicate the base-to-beltack information from the base stations' with their transmitters off to the base with its transmitters on.

## Master and Servant Base Stations

A **master base station** is one that the user has set its base number to 01 (Master) and has its transmitters on. A master base conveys base-to-beltack data to its beltacks and, via a base station link cable, relays the base-to-beltack data from base stations that have their base transmitters off. A master may support up to 7 additional base stations with their transmitters off. **There can be only one master base station in a network of base stations.** A master base will automatically set a 09 (default) base to a unique 02 to 08 servant number. If a base is already a servant the master will leave it at that same number.

Base Number	Function
01	Master
02	Servant
03	Servant
04	Servant
05	Servant
06	Servant
07	Servant
08	Servant
09	Unassigned (Default)

Table 6-3 Valid Base Number Settings

GROUP	1A	R1	Ch1	█
F1	M	R2	Ch12	□
T1	50mW	R3	SA	█
T2	50mW	R4	OFF	█

Figure 6-22

Status screen of a master designated base station. Note the "M" below the group number.

Anytime a base station is changed to be a master base it must be **POWER CYCLED** for the change to take affect.

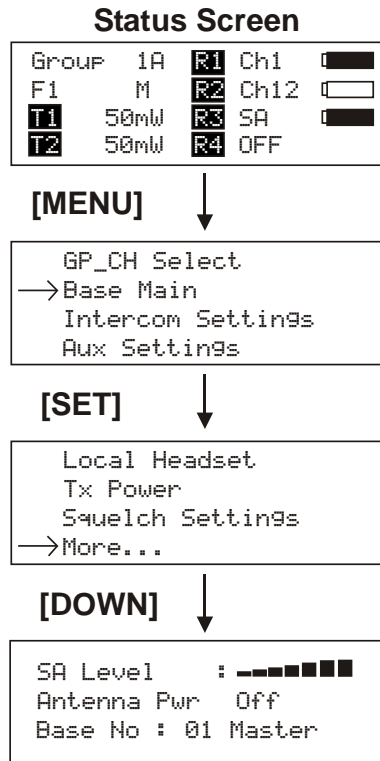
A **servant base station** is one that has its transmitters off and is connected to a master base. Since servant's base stations have their transmitters off, base-to-beltack information can only get to beltacks via link cables to a master base station. There can be up to seven servants that will work with one master base.

Group	1A	R1	Ch1	<input checked="" type="checkbox"/>
F1	02	R2	Ch12	<input type="checkbox"/>
T1	Off	R3	Ch1	<input checked="" type="checkbox"/>
T2	Off	R4	Ch2	<input checked="" type="checkbox"/>

**Figure 6-23**

Status screen of a servant base station. Note the servant number below the group number.

A servant or master base is set via the **Base Main** menu screen in the base station.



**Figure 6-24**

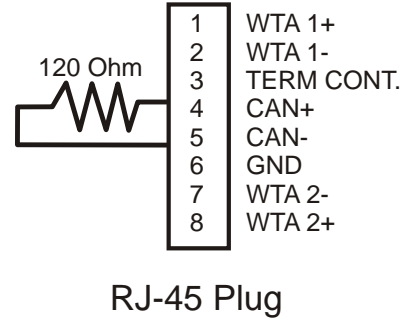
How to get to the master / servant selection screen.

From the factory, base stations are set to base number 09. This is an **unassigned base**. This base can be left as 09 if not in a linked system and will work normally with all features available to it. If connected to a master base station the master will automatically assign a valid, unique, servant ID to an unassigned base the first time the networked system is powered-up.

The master base must always power-up after the servant bases in order to detect that there are servant units to control. If all the units are on a common power strip, this is controlled by a built in delay on master base station. The master base station will always boot slower than servant units.

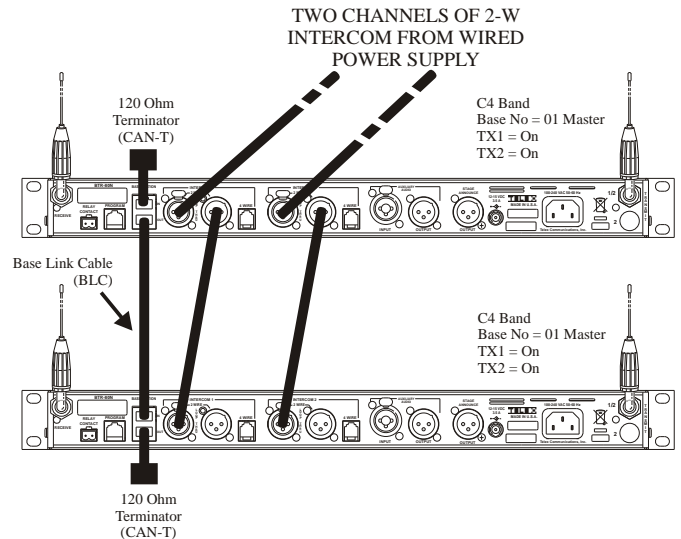
## CAN bus

A Controller Area Network (CAN) bus is the data protocol used over the BTR-80N's base station link cable. This balance protocol is a robust standard used the world over in high noise, extreme environments. It requires the use of 120 Ohm terminators at the beginning and end of a CAN bus network.



**Figure 6-25**

CAN Bus 120 Ohm termination (CAN-T) and base pin functions. Part Number: PRD000223002 (Not Supplied)



**Figure 6-26**

A base link cable connected system with terminators on both end.

## Base Station Link Configurations

Multiple base stations networks may be connected in different ways. Using the rear panel Base Station Link jacks, a user has three different connection options.



These options are:

- **Wireless Talk Around (WTA) Audio Only**
  - Bases connected via 2-wire and/or 4-wire audio links
  - All bases share WTA audio
  - They do **NOT** share CAN bus data.
  
- **WTA and a SINGLE CAN Bus Network**
  - Bases connected via 2-wire and/or 4-wire audio links
  - All bases share WTA audio
  - All bases are **ON A SINGLE CAN BUS NETWORK**.
  
- **WTA and Several CAN Bus Networks**
  - Bases connected via 2-wire and/or 4-wire audio links
  - All bases share WTA audio
  - There are **MORE THAN ONE CAN BUS NETWORK**.

## Base Station Link Jacks

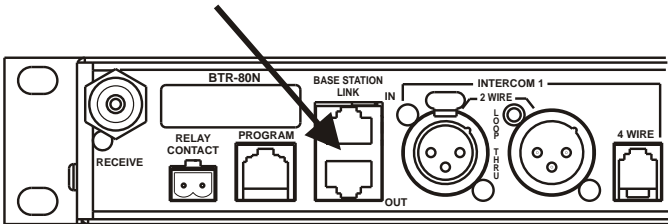


Figure 6-27

Base station link input and output jacks on the rear of the BTR-80N

## Wireless Talk Around (WTA) Audio Only

These base stations are connected to share WTA channel 1 and WTA channel 2 audio but do not share the CAN bus data.

### Link Overview

WTA 1 and WTA 2 audios in the BTR-80N are two independent 2-wire intercom channels. The WTA intercom channels are very similar to AudioCom types of intercom except they are dry and are meant to only pass audio between BTR-80N base stations. Up to 16 base stations may be connected together with base link cables (BLC) depending on cable length and conductor size. The BLC passes both channels of WTA audio. It also passes a logic level so the 1<sup>st</sup> base station in the chain is the only one that provides a termination of the WTA intercom channels. This pin is labeled “TERM CONT” on the

RJ-45 plug pin outs in this section. Care must be taken to connect cables between base stations from the OUT of base one to the IN of base two and so forth unit to unit. If the WTA link cable is passed from OUT to OUT or IN to IN the WTA audio will be terminated in multiple places and cause the WTA audio levels to be greatly reduced/distorted.

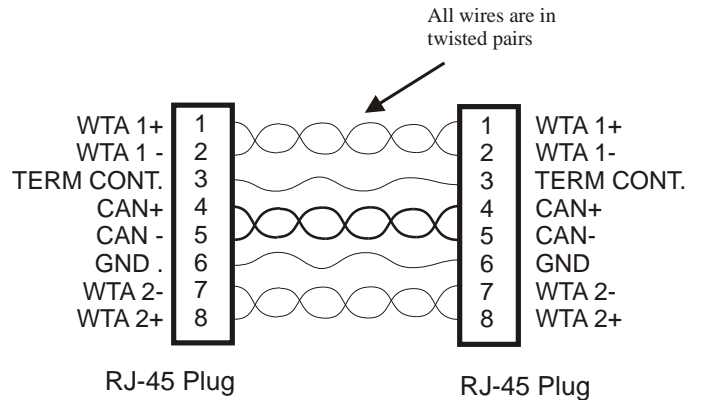


Figure 6-28

Base Link Cable (BLC) and pin functions. Part Number: PRD000223000 (Not Supplied).

If base stations are a longer distance apart, greater than the 12” (30.48 cm) BLC, then 568-A or 568-B Ethernet cables of CAT 5E or above may be use for the base link cables. These Ethernet cables contain 4 twisted pairs exactly like the BLC cable. Ethernet cables may be used to connected base stations that are up to 300 feet apart.

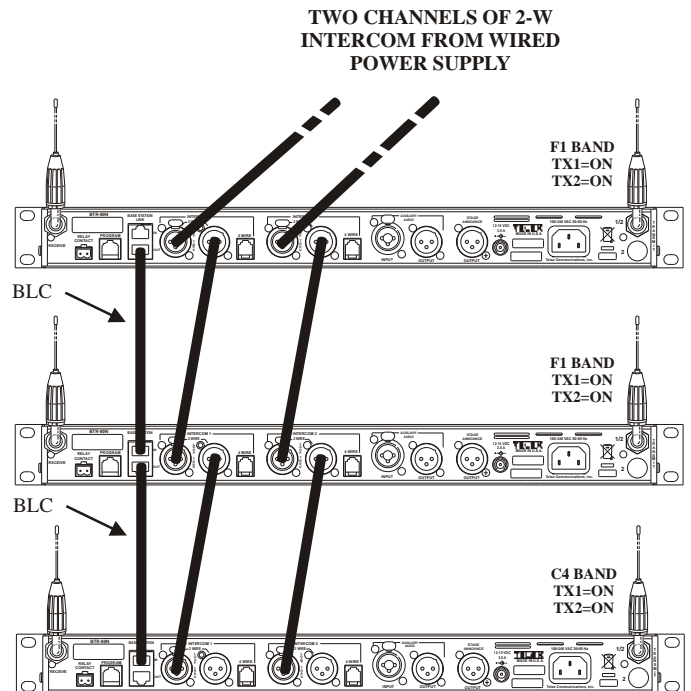


Figure 6-29

Multiple base stations connected via 2-wire audio cable and WTA through via BLCs.

The base station link does not need terminations if only WTA audio is planned to be passed between base stations. There also must not be any base stations set to base number 01 (Master). This is because CAN bus is connected through to the other base stations with a BLC as can be seen in the figure. If there are no masters on the CAN bus system, no activity will be on the CAN bus line, thus no need for terminations.

## Setup

1. Connect power to the base stations. Keep power off to the units.
2. Connect the transmit and receive antennas to the base stations. The color dots on the rear of the base should match the color ring of the antennas.
3. Connect the main intercom audio channel(s) to the base stations. This may be 2-wire intercom. This could also be 4-wire intercom via matrix type wired system.
4. Connect the Base Link Cable (BLC) between base stations. Remember to connect from the OUT of the 1<sup>st</sup> base station to the IN of 2<sup>nd</sup> base and follow the same connection pattern forward.
5. Power-up all the base stations.
6. The base stations should be set to all unique transmit and receive frequencies.
7. Setup via the BTR-80N software menus the intercoms, local headset, auxiliary, stage announce, etc. as detailed in "BTR-80N Operation" in Section 6.
8. All the base station numbers should be left as 09 (default).
9. Turn on a beltpack and only one beltpack. Try to keep the beltpacks at least 6' (2 meters) away from the base's antennas. Set the beltpack on the appropriate group and channel for its base station.

As each beltpack is set to its group and channel, an hourglass symbol will appear on the base display in the location normally occupied by the battery symbol. A beltpack will be assigned an ID number by the base in this time. Finally a normal battery symbol will be displayed, indicated the beltpack has been assigned its ID number.

10. Once this 1<sup>st</sup> beltpack has an ID number, turn it off. Now turn on the next beltpack and set it up as in step 9. Continue this same process until all the beltpacks are set to the proper group / channels and have been assigned their IDs. Now all the beltpacks may be powered-up.

END.

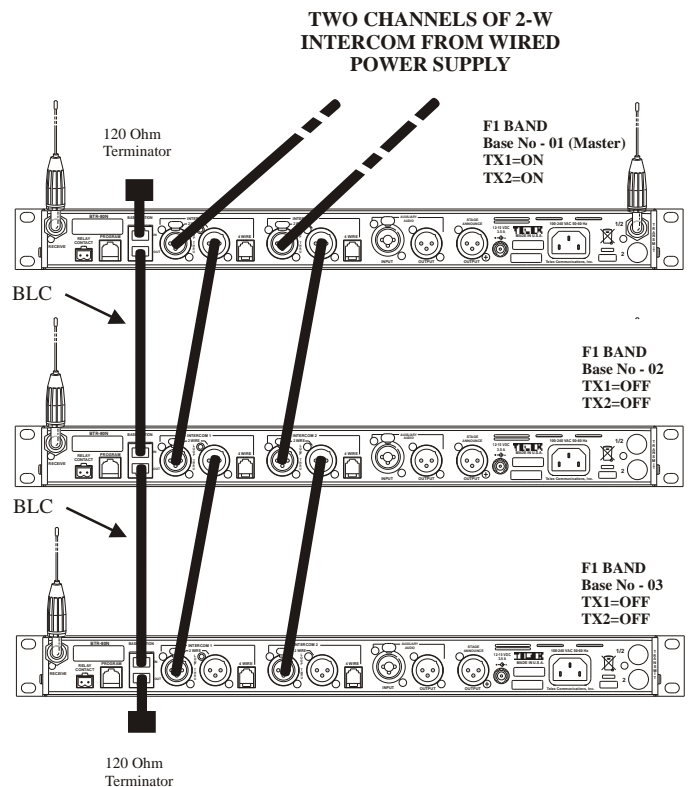
## WTA and a SINGLE CAN Bus Network

These base stations that may be connected via 2-wire and/or 4-wire audio links. They are also connected together via the Base Link Cable (BLC). This cable passes WTA audio and CAN bus data information. The CAN bus connected base stations together form a Network.

### Link Overview

There are two RF data communication links with a BTR-80N system. They are the beltpack-to-base and the base-to-beltpack links. The beltpack-to-base links convey information such as current button(s) selected, battery level, etc. The base-to-beltpack links convey beltpack user ID, beltpack TX shutdown, beltpack Talk shutdown and other information

These two data paths are intact when there is only one base communicating to beltpacks. They are also intact when many base stations on different TX and RX frequencies are communicating to their beltpacks. However when one or more base stations that have their transmitters off are connected to a base station with its transmitters on, the base-to-beltpack data link is lost for these beltpacks.



**Figure 6-30**  
Multiple base stations connected via 2-wire audio cable and WTA plus CAN through via BLCs.

Care must be taken to connect cables between base stations from the OUT of base one to the IN of base two and so forth unit to unit. If the WTA link cable is passed from OUT to OUT or IN to IN the WTA audio will be terminated in multiple places and cause the WTA audio levels to be greatly reduced/distorted.



The master base must always power-up after the servant bases in order to detect that there are servant units to control. If all the units are on a common power strip, this is controlled by a built in delay on master base station. The master base station will always boot slower than servant units.

## Setup

1. Connect power to the base stations. Keep power off to the units.
2. Connect the transmit and receive antennas to the base stations. The color dots on the rear of the base should match the color ring of the antennas.
3. Connect the main intercom audio channel(s) to the base stations. This may be 2-wire intercom. This could also be 4-wire intercom via matrix type wired system.
4. Connect the Base Link Cable (BLC) between base stations. Remember to connect from the OUT of the 1<sup>st</sup> base station to the IN of 2<sup>nd</sup> base and following the same connection pattern forward.
5. Place CAN bus termination plugs (CAN-T) at the beginning and end of the networked base stations.
6. Power-up all base stations and set all to factory defaults via a four button reset; [MENU] + [SET] + [UP] + [DOWN]. Now power down all the bases.
7. Power-up the 1<sup>st</sup> servant base station. Set the servant base station to all unique receive frequencies. The transmitters will be set to OFF automatically when the master base takes control of them. Leave the base number at the default of 09.
8. Setup via the BTR-80N software menus the intercoms, local headset, auxiliary, stage announce, etc. as detailed in "BTR-80N Operation" in Section 6. Leave the base station powered-up.
9. Power-up the master base station. Set the base to all unique transmit and receive frequencies. Setup via the BTR-80N software menus the intercoms, local headset, auxiliary, stage announce, etc. as detailed in "BTR-80N Operation" in Section 6.
10. Set the base station with its transmitters to be on to master, base number 01.
11. Cycle the power of the master base only, while leaving the single servant base powered-up.
12. The master base, on boot, will take control of the servant base and assign it the base ID of 02 and turn its transmitters off. Now proceed to power-up the next servant base station and go to step 7 above for each servant base. Always leave the previously assigned servant base stations powered-up when going on to the next base.

The **master base must always power-up after the servant bases** in order to detect that there are servant units to control. If all the units are on a common power strip, this is controlled by a built in delay on master base station. The master base station will always boot slower than servant units. Try to keep the beltacks at least 6' (2 meters) away from the base's antennas.

13. Turn on a beltack and only one beltack. Set the beltack on the appropriate group and channel for its base station.

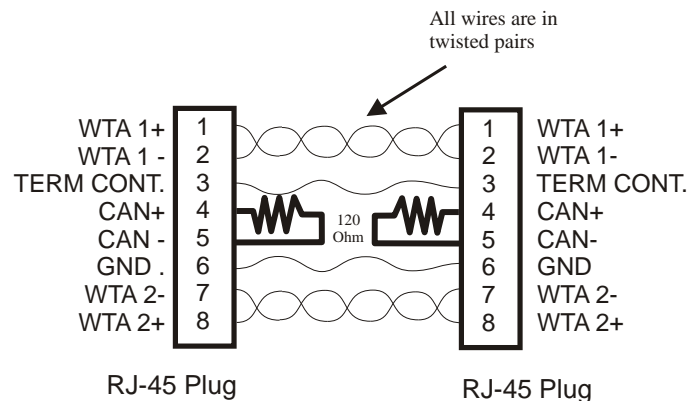
As each beltack is set to its group and channel, an hourglass symbol will appear on the base display in the location normally occupied by the battery symbol. A beltack will be assigned an ID number by the base in this time. Finally a normal battery symbol will be displayed, indicated the beltack has been assigned its ID number.

14. Once this 1<sup>st</sup> beltack has an ID number, turn it off. Now turn on the next beltack and set it up as in step 13. Continue this same process until all the beltacks are set to the proper group / channels and have been assigned their IDs. Now all the beltacks may be powered-up.

END.

## WTA and Several CAN Bus Networks

These base stations may be connected via 2-wire and/or 4-wire audio links. They are also connected together via the Base Link Cable (BLC) and a new cable called the CAN Bus Termination Cable (CTC).



**Figure 6-31**  
**CAN Bus Termination Cable (CTC). Part Number:**  
**PRD000223001 (Not Supplied)**

## Link Overview

Multiple masters on the same CAN bus is not allowed. The two different cables solve this issue. The BLC passes WTA audio and CAN bus data information. The CTC only passes WTA audio and also functions to terminate the CAN network on either side of it. This allows many separate CAN networks to share the same two WTA audio channels.

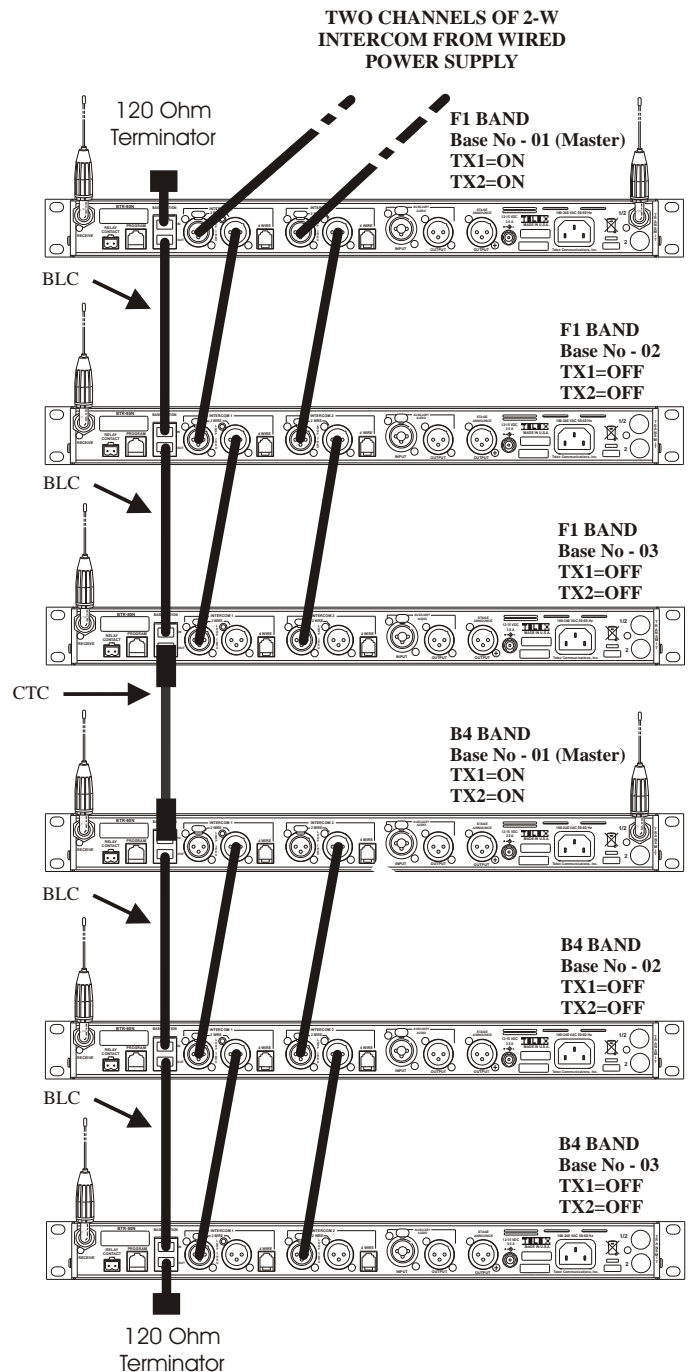
Care must be taken to connect cables between base stations from the OUT of base one to the IN of base two and so forth unit to unit. If the WTA link cable is passed from OUT to OUT or IN to IN the WTA audio will be terminated in multiple places and cause the WTA audio levels to be greatly reduced/distorted.

The master base must always power-up after the servant bases in order to detect that there are servant units to control. If all the units are on a common power strip, this is controlled by a built in delay on master base station. The master base station will always boot slower than servant units.

## Setup

Setup is the same as the previous, “WTA and a SINGLE CAN Bus Network” section with the exception of a CTC cable between the two CAN networks.

1. Connect power to the base stations. Keep power off to the units.
2. Connect the transmit and receive antennas to the base stations. The color dots on the rear of the base should match the color ring of the antennas.
3. Connect the main intercom audio channel(s) to the base stations. This may be 2-wire intercom. This could also be 4-wire intercom via matrix type wired system.
4. Connect the Base Link Cable (BLC) between base stations within a CAN network. Remember to connect from the OUT of the 1<sup>st</sup> base station to the IN of 2<sup>nd</sup> base and following the same connection pattern forward.
5. Connect the CAN Bus Termination Cable (CTC) **BE-TWEEN** the CAN networks. Remember to connect from the OUT of the base station to the IN of next base.
6. Place CAN bus termination plugs (CAN-T) at the beginning and end of the multiple connected networks.
7. Power-up all base stations and set all to factory defaults via a four button reset; [MENU] + [SET] + [UP] + [DOWN]. Now power down all the bases.



**Figure 6-32**  
**Multiple base stations connected via 2-wire audio cable and two CAN Bus networks.**

8. For the 1<sup>st</sup> network of base stations, power-up the 1<sup>st</sup> servant base station. Set the servant base station to all unique receive frequencies. The transmitters will be set to OFF automatically when the master base takes control of them. Leave the base number at the default of 09.
9. Setup via the BTR-80N software menus the intercoms, local headset, auxiliary, stage announce, etc. as detailed in “BTR-80N Operation” in Section 6. Leave the base station powered-up.

10. Power-up the master base station. Set the base to all unique transmit and receive frequencies. Setup via the BTR-80N software menus the intercoms, local headset, auxiliary, stage announce, etc. as detailed in “BTR-80N Operation” in Section 6.
11. Set the base station with its transmitters to be on to master, base number 01.
12. Cycle the power of the master base only, while leaving the single servant base powered-up.
13. The master base, on boot, will take control of the servant base and assign it the base ID of 02 and turn its transmitters off. Now proceed to power-up the next servant base station and go to step 8 above for each servant base. Always leave the previously assigned servant base stations powered-up when going on to the next base.

The **master base must always power-up after the servant bases** in order to detect that there are servant units to control. If all the units are on a common power strip, this is controlled by a built in delay on master base station. The master base station will always boot slower than servant units.

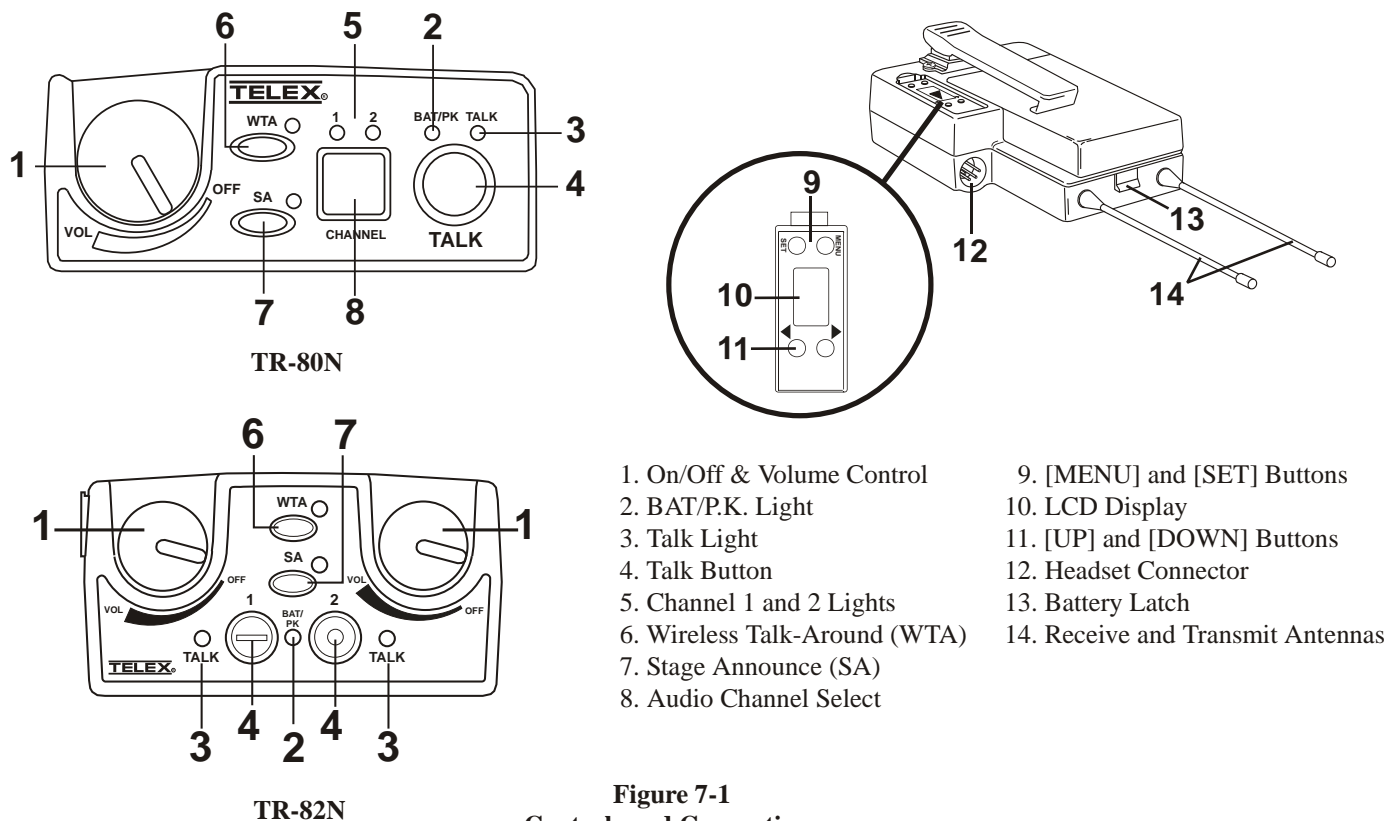
14. Go to step 8 above for each additional network.
15. Turn on a beltpack and only one beltpack on the 1<sup>st</sup> network system. Try to keep the beltpacks at least 6' (2 meters) away from the base's antennas. Set the beltpack on the appropriate group and channel for its base station.

As each beltpack is set to its group and channel, an hourglass symbol will appear on the base display in the location normally occupied by the battery symbol. A beltpack will be assigned an ID number by the base in this time. Finally a normal battery symbol will be displayed, indicated the beltpack has been assigned its ID number.

16. Once this 1<sup>st</sup> beltpack has an ID number, turn it off. Now turn on the next beltpack and set it up as in step 15. Continue this same process until all the beltpacks with the different networks are set to the proper group and channels and have been assigned their IDs. Now all the beltpacks may be powered-up.

END.





1. On/Off & Volume Control
2. BAT/P.K. Light
3. Talk Light
4. Talk Button
5. Channel 1 and 2 Lights
6. Wireless Talk-Around (WTA)
7. Stage Announce (SA)
8. Audio Channel Select

9. [MENU] and [SET] Buttons
10. LCD Display
11. [UP] and [DOWN] Buttons
12. Headset Connector
13. Battery Latch
14. Receive and Transmit Antennas

**Figure 7-1**  
Controls and Connections

## Basic Operational Description

The TR-80N/82N is a full duplex (simultaneous talk and listen) beltpack that works in conjunction with a BTR-80N base station. The beltpack allows a user, via a headset attached to the beltpack, to communicate with other wireless or wired users. Other base stations and / or wired systems connect to the beltpack's base station. The base station is what allows the audio path interconnections for the beltpack audio.

The TALK, WTA (wireless talk around) and SA (stage announce) buttons on a beltpack turn the beltpack's microphone input on or off. They also select the audio paths for the beltpack's audio in the base.

## System Quick Start

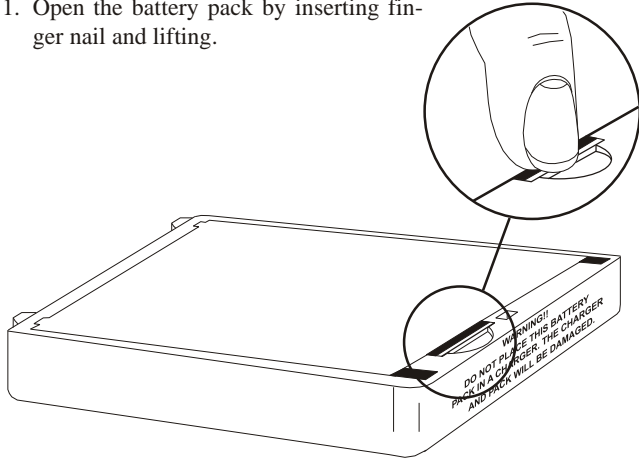
The following is a list to quickly get a base station and beltpacks operating.

1. Unpack the base and connect the power cord and antennas.
2. Connect base to audio interfaces. For example; 2-wire, 4-wire, SA, Auxiliary local headset.
3. Press and hold [MENU] as powering-up the base station. Release button when base station displays "...FACTORY SETUP...".
4. Press [MENU] as powering-up the beltpack(s)
5. Use the [UP] and [DOWN] arrow button to change the channel to an unoccupied receive channel on the base station. Then press [SET] twice to set channel and group.
6. The base should now display the audio channel of the beltpack and a battery symbol will appear shortly.
7. Plug a headset into each beltpack. Adjust the software menu for microphone gain so the overmodulation light flashes only on some of the words at normal speech levels.

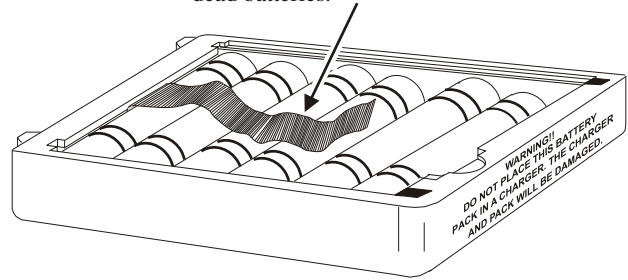
# Battery Installation

Ensure that the On/Off volume control knob is turned off. Press down and hold down the battery release latch, slide the battery pack about 1/8 inch back, toward the latch, until it stops. Then lift battery pack out. Replace batteries as follows:

1. Open the battery pack by inserting finger nail and lifting.



2. Pull battery strap to remove low or dead batteries.

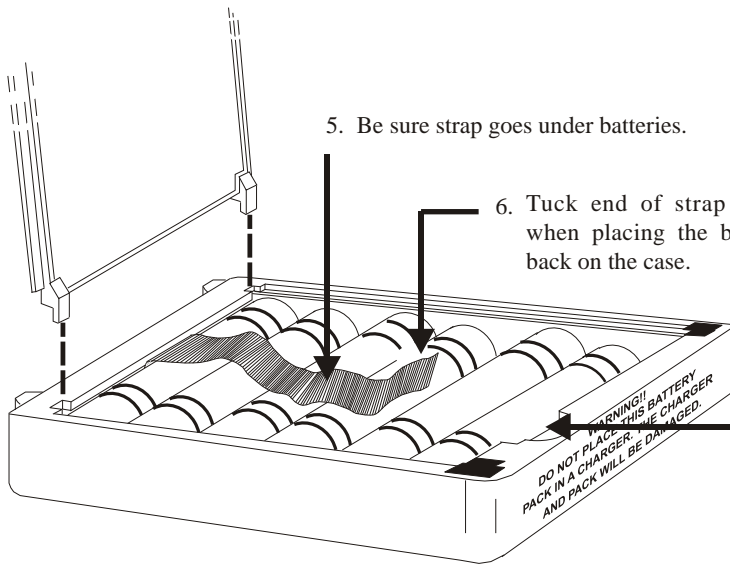


3. Load new batteries following the polarity as shown in battery case



5. Be sure strap goes under batteries.

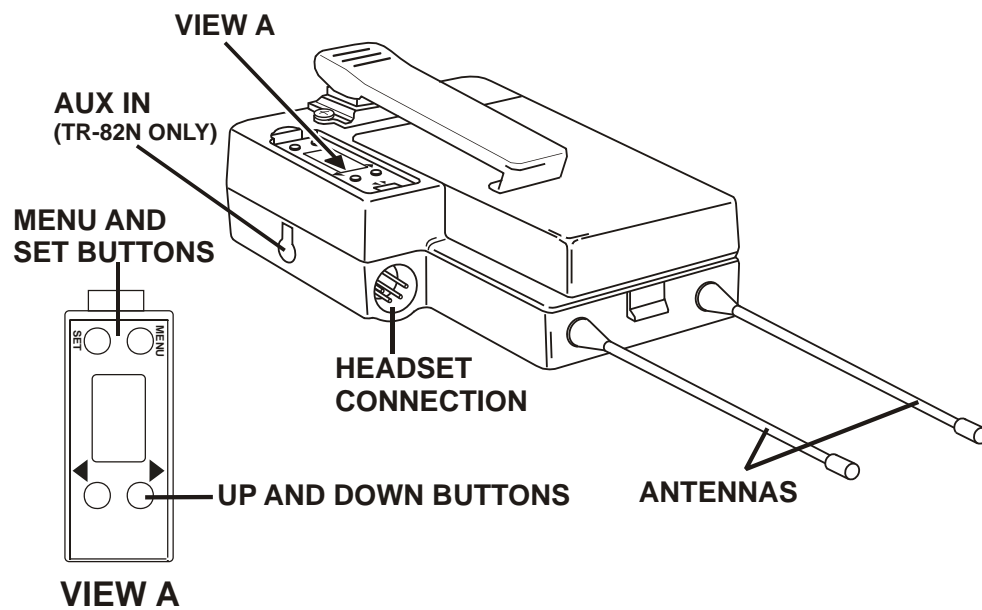
6. Tuck end of strap under door when placing the battery cover back on the case.



4. Start loading at the end of the case where the strap is attached to the case.

**Figure 7-2**  
**Battery Installation**

**WARNING:** Do not place an alkaline TR battery pack in any battery charger. Severe charger and batter pack damage may results.



**Figure 7-3**  
TR-80N/82N Controls

## Headset Connection

The headset connector is a XLR type connector. Four or five pin Telex or RTS headset connectors may be installed in the unit. See the “TR-80N/82N Controls and Connections” section for information on the pinouts. A dynamic or electret headset microphone is automatically detected by the beltpack and a bias voltage supplied if needed.

## Sidetone

Sidetone is the amount of the users voice that is fed back to their headphone. The sidetone level in the beltpack and base station is fixed. It cannot be adjusted.

## Antenna Connection

The beltpack comes with two detachable, screw type ¼ wave antennas. Attach the two antennas by screwing the antennas into the receptacles at the bottom of the beltpack. The color dot on the screw end of the antenna must match the color dot on the antenna receptacle.

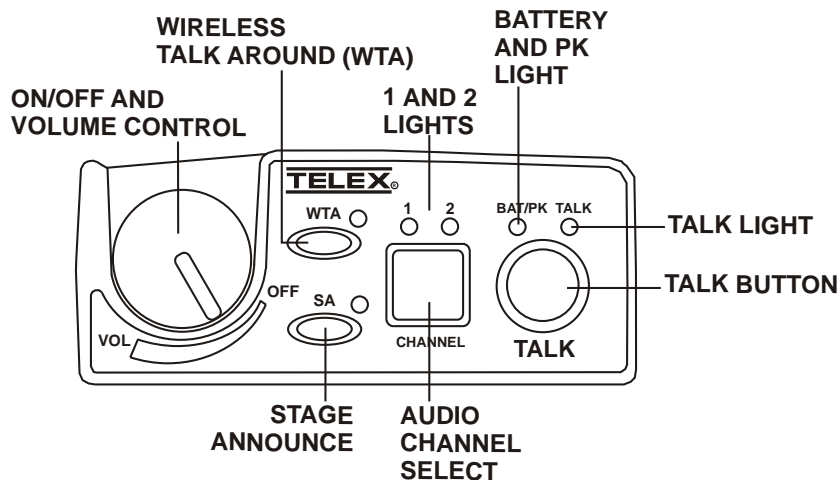


Figure 7-4  
TR-80N Top Panel Controls

### On/Off and Volume Control

Turn the belpack power on by rotating the knob CW. Adjust the volume to the headset by rotating the volume control as required for a comfortable listening volume.

<b>Battery</b>	Light flashes on power up	= Battery OK
	Light on continuously	= Battery Low
	Light does not flash or come on	= Battery Dead
<b>Over modulation</b>	Light flashes on some speech	= Gain OK
	Light flashes on all speech	= Gain too high
	Light never flashes on speech	= Gain too Low

### Talk Button

Press to enable audio path from the headset microphone. The talk light will activate when the talk button is active.

The talk button has three software selectable modes that can be seen via the LCD display of the belpack. The mode of the talk button may be selected by pressing and holding [SET] while hitting the talk button. The current mode of the talk button will be displayed the first time the talk button is hit. Hit the talk button again to change the mode of the button. Release the [SET] button to accept the currently displayed setting.

<b>Selectable Modes: TALK</b>	tb off	Talk disabled
	tb Ptt	Push-to-talk
	tb LAt	Push-to-latch

### Audio Channel Select Button

Selects the intercom system to which the headset is connected. The LED near the channel button indicates the current selection.

The audio channel select has three options. The options may be selected by pressing and holding [SET] while hitting the channel select button. The current mode of the channel select button will be displayed the first time the button is hit. Hit the button again to change the mode of the button. See table below for the options. Release the [SET] button to accept the currently displayed setting.

<b>Selectable Modes: AUDIO CHANNEL BUTTON</b>	12 on	Channels 1 and 2 available
	1 on	Only channel 1
	2 on	Only channel 2

### Stage Announce (SA)

When pressed the audio from the belpack is routed directly to the stage announce connector on the back of the base station. The base station's SA relay is also closed. The belpack sidetone is lost as an indication that stage announce is activated. The other belpacks and wired users do not hear this belpack's audio when SA is pressed. The button is non-latching and activates the nearby red LED when pressed.

To Enable or Disable Stage Announce, press and hold [SET] while hitting the SA button. The current mode of the [SA] button will be displayed. Press the [SA] button again to turn SA on or off. Release [SET] to accept the displayed setting.



## Wireless Talk Around (WTA)

When pressed, the audio from the beltpack is disconnected from the wired intercom, auxiliary input/output and the base station's local headset. Other beltpack users, on that audio channel, can hear the user as normal. The button activates the nearby red LED as well as the appropriate talk LED when pressed.

To Enable or Disable Wireless Talk Around options, press and hold [SET] while hitting the [WTA] button. The current WTA mode will be displayed. Press WTA again to change modes. Available options are: Off, on and Lon (Latch on). Release [SET] to accept the displayed setting.

## Groups and Channels

The first LCD screen the beltpack displays is the group / channel screen. This screen shows the currently selected receive group followed by the beltpack transmit channels.

### Editing Groups / Channels

1. Push [SET] to edit the transmit channel. The channel number will begin flashing.
2. Select the desired channel with the, [UP]/[DOWN] arrow buttons.
3. Push [SET] to accept the channel. The receive group will now begin flashing.
4. Select the desired group with arrow buttons.
5. Push [SET] to accept the receive group.
6. The new group containing the selected channel is now set.

**NOTE:** Pressing [MENU] during the group/channel editing will bail out of the editing without any changes.

Factory group's frequencies are not changeable.  
User group's (Group 19u to 30u) frequencies are changeable.

## Transmit Frequency

This screen displays the frequency in MHz of the beltpack transmitter. The frequency is not changeable in factory-defined groups. The frequency is changeable in user-defined groups.

### Editing the TX Frequency (User Groups Only)

1. Set the unit to the desired user defined group and channels; see Groups and Channels Instructions. The menu structure at the right (Figure 7-5) indicates how to get to the transmit frequency screen.
2. Push [SET] to edit the TX frequency. The frequency will begin flashing.
3. Select the desired frequency with the [UP]/[DOWN] arrow buttons. The frequency can be changed in 25 kHz steps.
4. Push [SET] to place the unit on the new transmit frequency.

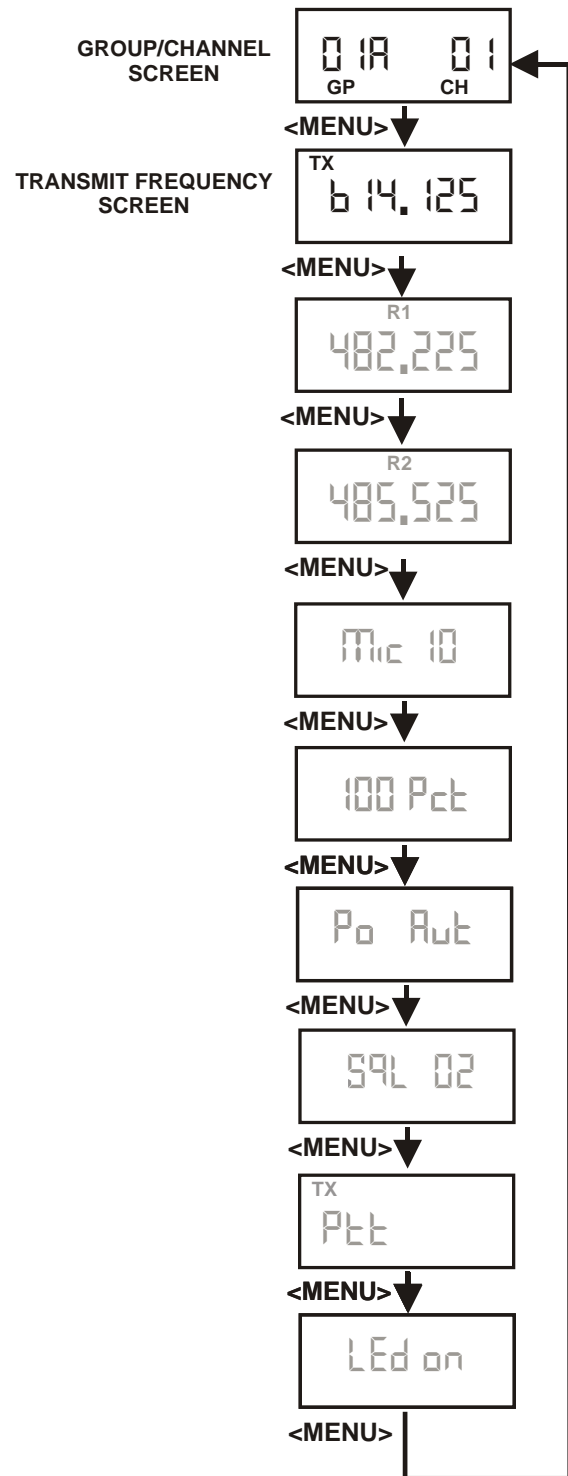


Figure 7-5  
Group/Channel and Transmit Frequency Screen

## Receive Frequencies

This screen displays the frequency in MHz of the beltpack receiver. The frequency is not changeable in factory defined groups. The frequency is changeable in user-defined groups.

### Editing the RX Frequency (User Groups Only)

1. Set the unit to the desired user defined group and channels. See Groups and Channels Instructions. The menu structure at the right (Figure 7-6) indicates how to get to the receive frequency screen.
2. Push [SET] to edit the RX frequency. The frequency will begin flashing.
3. Select the desired frequency with the [UP]/[DOWN] arrow buttons. The frequency can be changed in 25 kHz steps.
4. Push [SET] to place the unit on the new receive frequency.

## Microphone Gain

This screen displays the setting of the microphone gain of the beltpack. There are 16 possible settings. The number 0 indicates minimum microphone gain, the number 15 is maximum gain. Each step is about 3 dB.

### Adjusting the Microphone Gain

1. Push [SET] at the microphone gain screen. The number will begin flashing.
2. Select the desired gain with the [UP]/[DOWN] arrow buttons.
3. Push [SET] to place the unit at the indicated microphone gain.

## Battery Display

The battery display screen indicates the current percentage of battery remaining.

### Battery Percentages

- 100 Pct = Fresh Battery
- 75 Pct = 75 % Life Left
- 50 Pct = 50 % Life Left
- 25 Pct = 25 % Life Left
- 10 Pct = 10 % Life Left. Low Battery Light Active.
- 0 Pct = Battery Dead. Unit will lose communication at any time.

### Setting the Low Battery Alert Tone

The beltpack has an audio alert tone that is sent to the headphone if the battery life reaches 10 %. The tone is at 1 kHz and is heard for 0.5 seconds every 30 seconds. The tone is only heard at the beltpack. The alert tone function may be turned on or off at the beltpack:

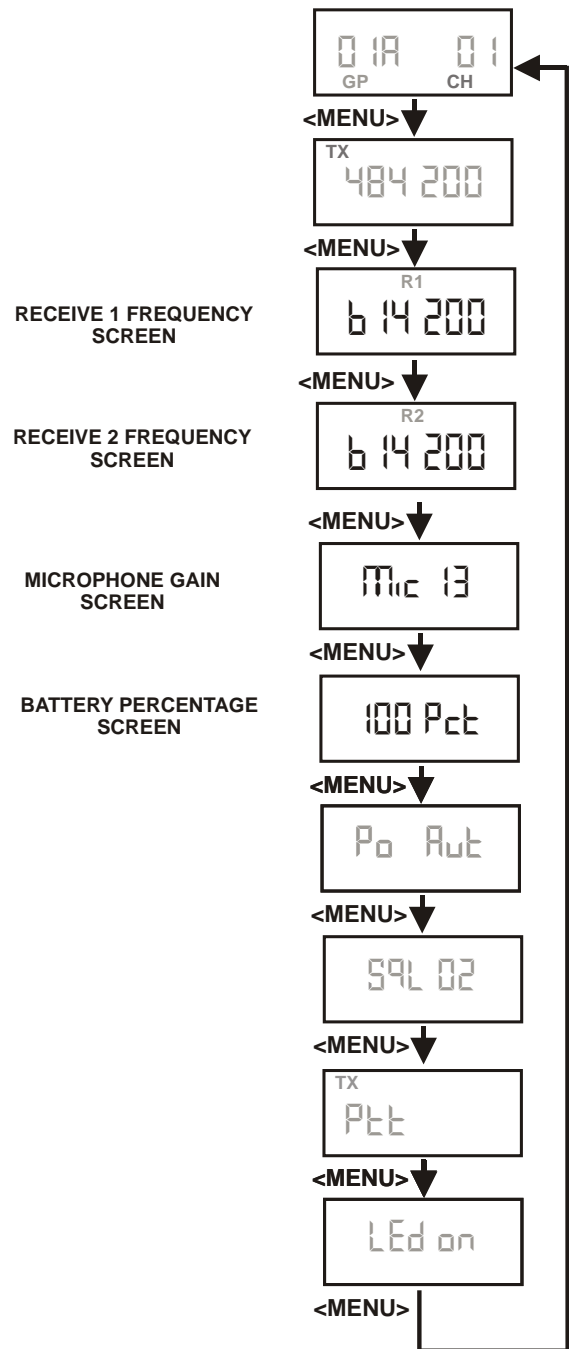


Figure 7-6  
Receive Frequencies/Microphone Gain/  
Battery Percentage Screens

## Low Battery Alert Tone and Battery Type

1. Press [SET] at the battery percentage screen. The screen below will appear.



2. The low battery tone option will also begin flashing.
3. Use the [UP]/[DOWN] arrow buttons to turn the option on or off.
4. Press [SET] to accept the change.



5. The screen now displays with AL or ni Flashing. Use [up]/[down] to select AL or ni for Alkaline/NiMH battery gauge calibration.
6. Press [SET] to return to the battery gauge screen.

## Transmit Power

The transmit power screen displays the current setting of the beltpack transmitter's output power level. There are four settings.

### Transmit Power Settings

Auto (Default)	The beltpack's transmitter adjusts its output level according to information sent to the beltpack from the base station. It adjust between two levels: 5mW or 50mW.
5	The beltpack is transmitting at 5 mW
50	The transmitter is at 50 mW
100	The transmitter is at 100 mW

When the unit is set to auto, base station information will tell the beltpack the appropriate power setting to use based upon received signal strength level at the base station. By reducing the transmit power when possible, the battery life of the beltpack can be slightly extended and intermodulation products can be reduced.

### Changing the Transmit Power Setting

1. Push [SET] at the transmit power screen. The power setting will begin flashing.
2. Select the power setting with the [UP]/[DOWN] arrow buttons.
3. Push [SET] to place the unit at the indicated setting.

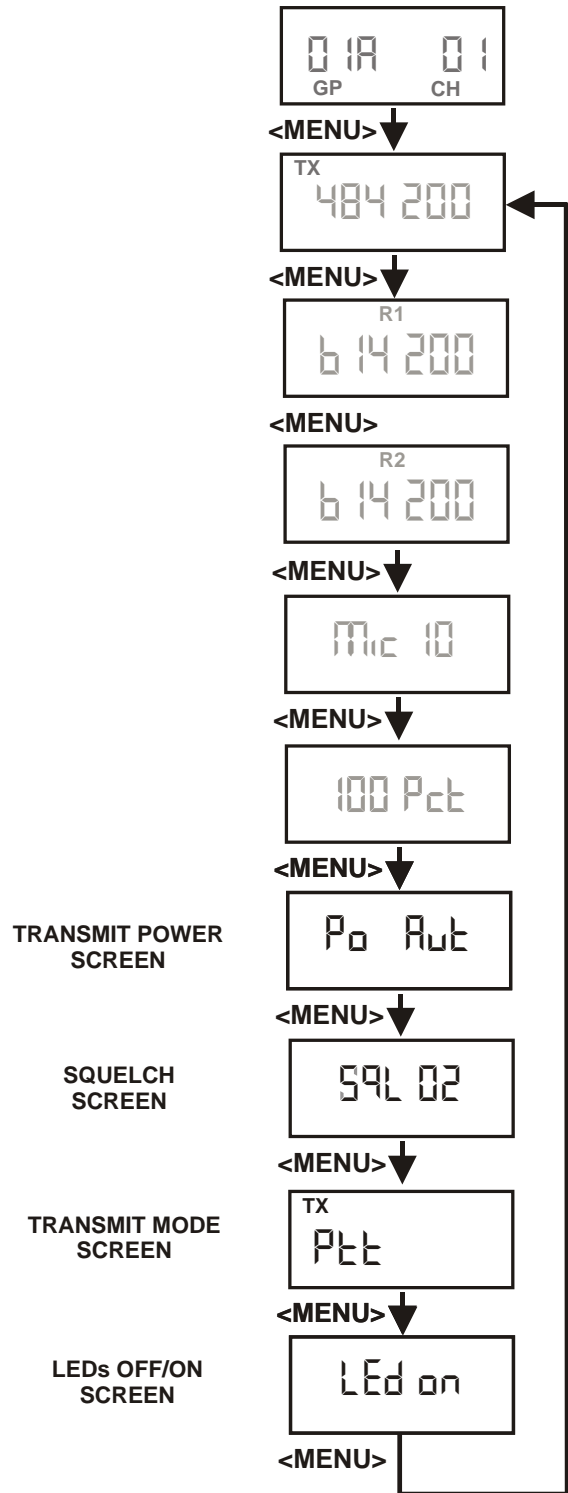


Figure 7-7  
Transmit Power, Squelch,  
Push-to-Talk/Push-to-Transmit Screen

## Squelch Screen

The squelch screen allows the user to adjust the beltpack squelch level.

1. Push [SET] at the squelch screen. The squelch setting will begin flashing.
2. Use the [UP]/[DOWN] buttons to select the desired squelch setting. 1 is minimum squelch, 04 is maximum. A setting of 00 will hold the squelch open for testing.  
**Warning - do not set the squelch to 00 while wearing headphones with the volume turned up. White noise with no signal can be uncomfortably loud.**
3. Push [SET] to save the new squelch setting.

Squelch Lvl	Approx. SINAD	Notes
00	NA	Open
01	12	
02	20	Default
03	24	
04	NA	RSSI Lvl Squelch

Squelch Note: The beltpack employs two different types of squelches. A fast acting noise type squelch and a slower data squelch. For audio to be received by the beltpack both a good signal-to-noise audio signal (with a noise threshold set via the usersquelch settings above) and a valid data stream must be detected.

## Transmit Mode Screen

Transmit mode screen is used to select the following modes:

Transmit Mode	Description
Ptt	Push-to-Talk. The transmitter is always on and the talk button un-mutes the audio when on. The beltpack will respond to the audio mute commands from the base.  When a user disables the Portable Station Connect button corresponding to the beltpack the talk button at the beltpack will shut down.
Ptt Tr	Push-to-Transmit. The transmitter is off and audio muted until the talk button is on. The beltpack will ignore lockout or shutdown commands from the base.
Ptt TrL	Push-to-Transmit Lockout Enabled. The transmitter is off and audio muted until the talk button is on. The beltpack will respond to lockout commands from the base, such as First-On-Latch Out and Portable Station Connect disable.

Changing the transmit mode setting:

1. Push [SET] at the transmit mode screen. The screen will begin flashing.
2. Use the [UP]/[DOWN] buttons to select the desired mode.
3. Push [SET] to save the mode change.

## LEDs Off/On

The LED off/on screen is used to disable all LEDs. This function is useful for users who do not wish to show LEDs in the dark.

1. Push [SET] at the LED on/off screen. The on/off will begin flashing.
2. Use the [UP]/[DOWN] buttons to select the desired mode.
3. Push [SET] to save the mode change.

## Software Version/ Band

The software revision and frequency band of the beltpack may be displayed from any of the main beltpack screens.

### Viewing the Software Revision and Frequency Band

1. In any of the beltpack main screens press and hold the [DOWN] button for 2 seconds.
2. The first screen indicates the frequency band of the beltpack. The second screen indicates the software revision. The screens below indicate that it is an E5 band beltpack with 80E052 version software.
3. The screen will now revert back to the main screen.

bnd E5

80E 052

## ClearScan

ClearScan helps you find clear RF frequencies in your area. The beltback's receiver scans all the factory defined groups and any user defined groups that have been set. The result is a list of beltback receive groups that are clear of interference.

### Entering ClearScan

1. Press and hold [MENU] + [SET] for 2 seconds to start ClearScan
2. The beltback display will change to "ClrScn" and the GP icon will flash.
3. After about 12 seconds, the beltback will display the first clear group. The group number will be flashing.
4. Use the [UP]/[DOWN] buttons to display other clear groups.
5. Select a group by pressing [SET]
6. Press [MENU] to bail out without selecting a group.

Clear groups are displayed first. They are in group order. You can scroll down through groups using the [DOWN] button. The right half of the screen will give you an indication of interference levels as you scroll through the groups.

User-defined groups that do not have a frequency defined for one of the receive channels will display 'u' to indicate it is "undefined".

The degree of interference found for R1 and R2 will be displayed on the right two most positions on the screen. See chart below:

Interference Level	Right Half of LCD Display
None	Blank
Weak	Single bar
Moderate	Double bar
Strong	Triple bar

## Lock Out

This function allows the user to lock the top panel and menu options. The top panel buttons will still work but the talk button options can not be changed. Likewise, values on the LCD screen in the beltback can be viewed but not changed.

### Enabling / Disabling Lock Out

1. Press and hold the [UP] and [DOWN] buttons for two seconds. The word "Loc on" will appear on the screen when lock out is active.
2. Press and hold the [UP] and [DOWN] button for two seconds again to disable lock out. The word "Loc off" will appear.

## 1st Use Default

This function sets the beltback to Group 1A, channel 1 and leaves any user-programmed groups in memory. It will set unit to factory-defined menu settings. It will also set the "Talk" buttons to their default modes.

### Activating 1<sup>st</sup> Use Default

1. Press and hold the [MENU] button while powering-up the beltback.

## Factory Reset

This function sets the beltback to Group 1A, channel 1 and **ERASES** any user defined groups in memory. It will set a unit to factory settings. It will also set the "Talk" buttons to their default modes.

### Activating Factory Reset

1. Press and hold the [MENU] + [SET] + [UP] + [DOWN] for three seconds.

## RF Monitor Screen

Press and hold the [MENU] button for 2 seconds to display beltback RF Status. If the channel button is set to "1" then signal strength displayed is for R1 frequency. If the channel button is set to "2" then signal strength displayed is for R2 frequency.

TX Power	Signal Strength
L □ = 5mW	0 = No
h □ = 50mW	1 = Very Weak
H □ = 100mW	2 = Weak
	3 = Moderate
	4 = Strong
	5 = Very Strong

Press the [MENU] button again to exit RF Monitor Screen.

## Setting Beltpack ID

Several functions require the beltpack to know which base and channel it is associated with.

1. Auto Power Setting: The beltpack reduces its TX power when close to the base. Beltpack transmit power must be set to Auto.
2. Portable Station Deselect: The base can disable the TALK button of a beltpack. This shuts off the mic in PTT mode and turns off the transmitter in PT TR mode.
3. First-On-Latch-Out: This locks a base receive channel so that only one beltpack can transmit on the frequency at a time. A beltpack attempting to talk on top of another beltpack on the same frequency will hear a double beep in their headset.

A beltpack will try to establish its ID automatically when its group/channel is changed. The base must be on for this to work.

To check or set beltpack ID manually:

1. Press and hold [UP] for 2 seconds. The LCD will display 'id' 'Base '--' Receiver'. For example: "Id 1-3" means Base #1, Receiver #3.
2. If the LCD displays "Id ---" or does not match the base and receiver the beltpack is assigned to, Auto Power, Portable Station Deselect and First-On-Latch Out will not work correctly.
3. If the beltpack id is correct, press [MENU] to exit.
4. If the beltpack id is not correct, press [SET] and the id numbers will flash.
5. Use the [UP] or [DOWN] buttons to select a new id.
6. Press [SET] to apply the new id.

Bases with transmitters enabled are always base #1. A second base using the first base transmitters instead of its own, and properly connected to the first base thru CAN bus link cables becomes BASE #2, etc.

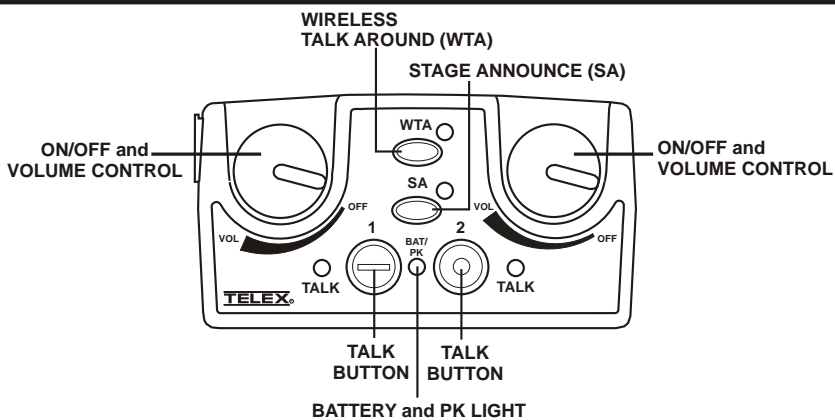


Figure 7-8  
TR-80N/82N Top Panel Controls

### On/Off and Volume Controls

Turn the beltpack power on by rotating either or both of the knobs CW. Adjust the volume to the headset by rotating the volume controls as required for a comfortable listening volume. Left control is for channel 1. Right control is for channel 2.

### Bat/Peak Light

See the following table for the light's function.

<b>Battery</b>	Light flashes on power up	= Battery OK
	Light on continuously	= Battery Low
	Light does not flash or come on	= Battery Dead
<b>Over modulation</b>	Light flashes on some speech	= Gain OK
	Light flashes on all speech	= Gain too high
	Light never flashes on speech	= Gain too Low

### Talk Buttons

Press to enable audio path from the headset microphone. The talk light will activate when the talk button is active.

Each talk button has three software selectable modes that can be seen via the LCD display of the beltpack. The mode of a talk button may be selected by pressing and holding [SET] while hitting the talk button. The current mode of the talk button will be displayed the first time the talk button is hit. Hit the talk button again to change the mode of the button. Release the [SET] button to accept the currently displayed setting.

<b>Selectable Modes: TALK</b>	1 or 2 off	Talk disabled
	1 or 2 on	Push-to-talk
	1 or 2 Lon	Push-to-latch

### Stage Announce (SA)

When pressed the audio from the beltpack is routed directly to the stage announce connector on the back of the base station. The base station's SA relay is also closed. The beltpack sidetone is lost as an indication that stage announce is activated. The other beltpacks and wired users do not hear this beltpacks audio when SA is pressed. The button is non-latching and activates the nearby red LED when pressed.

To Enable or Disable Stage Announce, press and hold [SET] while hitting the SA button. The current mode of the SA button will be displayed. Press the SA button again to turn SA on or off. Release [SET] to accept the displayed setting.

### Wireless Talk Around (WTA)

When pressed, the audio from the beltpack is disconnected from the wired intercom, auxiliary input/output and the base station's local headset. Other beltpack users, on that audio channel, can hear the user as normal. The button activates the nearby red LED as well as the appropriate talk LED if configured to do so.

To set Wireless Talk Around options, press and hold [SET] while hitting the WTA button. The current WTA mode will be displayed. Press WTA again to change options:

Options followed by "L" will latch. Release [SET] to accept the displayed setting.

tA Pb	WTA of currently selected talk button
tA 1L	WTA Channel 1only Latching
tA 2L	WTA Channel 2 only Latching
tA 12L	WTA Channel 1 & 2 Latching
tA PbL	WTA of currently selected talk button Latching
tA off	WTA Disabled
tA1	WTA Channel 1
tA2	WTA Channel 2
tA12	WTA Channel 1 & 2



## Groups and Channels

The first LCD screen the beltback displays is the group / channel screen. This screen shows the currently selected receive group followed by the beltback transmit channel.

### Editing Groups / Channels

1. Push [SET] to edit the transmit channel. The channel number will begin flashing.
2. Select the desired channel with the, [UP]/[DOWN] arrow buttons.
3. Push [SET] to accept the channel. The receive group will now begin flashing.
4. Select the desired group with arrow buttons.
5. Push [SET] to accept the receive group.
6. The new group containing the selected channel is now set.

**NOTE:** Pressing [MENU] during the group/channel editing will bail out of the editing without any changes.

Factory group's frequencies are not changeable.  
User group's (Group 19u to 30u) frequencies are changeable.

## Transmit Frequency

This screen displays the frequency in MHz of the beltback transmitter. The frequency is not changeable in factory defined groups. The frequency is changeable in user-defined groups.

### Editing the TX Frequency (User Groups Only)

1. Set the unit to the desired user defined group and channels; see Groups and Channels Instructions. The menu structure at the right (Figure 7-9) indicates how to get to the transmit frequency screen.
2. Push [SET] to edit the TX frequency. The frequency will begin flashing.
3. Select the desired frequency with the [UP]/[DOWN] arrow buttons. The frequency can be changed in 25 kHz steps.
4. Push [SET] to place the unit on the new transmit frequency.

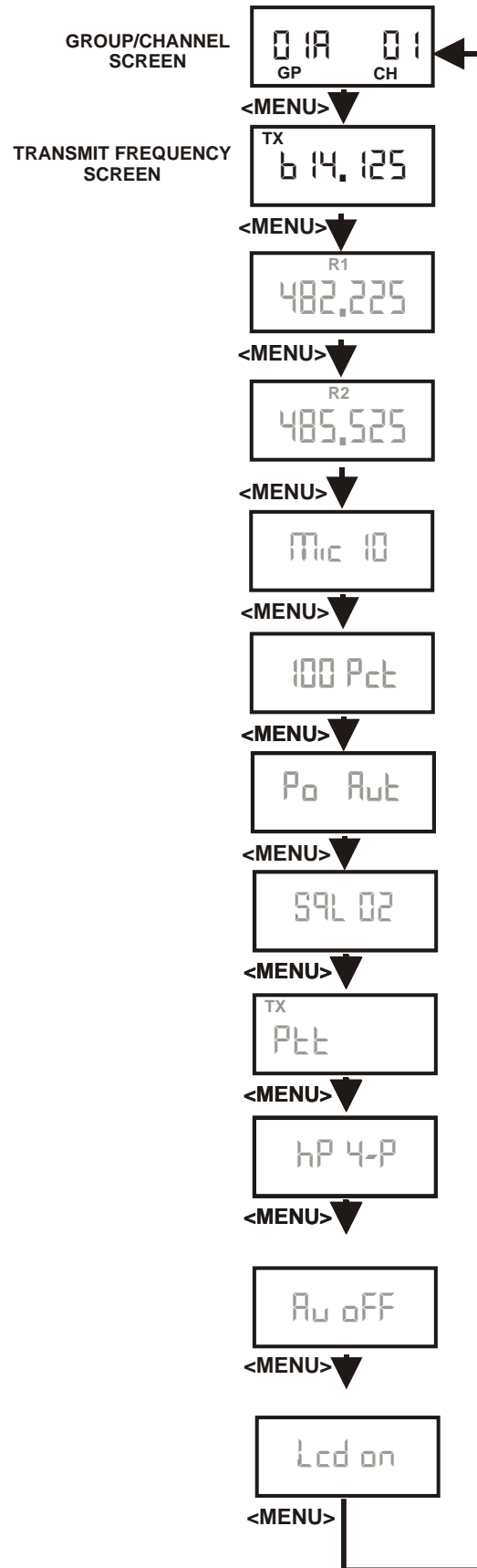


Figure 7-9  
Group/Channel and Transmit Frequency Screen



## Receive Frequencies

This screen displays the frequency in MHz of the beltpack receiver. The frequency is not changeable in factory defined groups. The frequency is changeable in user-defined groups.

### Editing the RX Frequency (User Groups Only)

1. Set the unit to the desired user defined group and channels. See Groups and Channels Instructions. The menu structure at the right (Figure 7-10) indicates how to get to the receive frequency screen.
2. Push [SET] to edit the RX frequency. The frequency will begin flashing.
3. Select the desired frequency with the [UP]/[DOWN] arrow buttons. The frequency can be changed in 25 kHz steps.
4. Push [SET] to place the unit on the new receive frequency.

## Microphone Gain

This screen displays the setting of the microphone gain of the beltpack. There are 16 possible settings. The number 0 indicates minimum microphone gain, the number 15 is maximum gain. Each step is about 3 dB.

### Adjusting the Microphone Gain

1. Push [SET] at the microphone gain screen. The number will begin flashing.
2. Select the desired gain with the [UP]/[DOWN] arrow buttons.
3. Push [SET] to place the unit at the indicated microphone gain.

## Battery Display

The battery display screen indicates the current percentage of battery remaining.

### Battery Percentages

- 100 Pct = Fresh Battery
- 75 Pct = 75 % Life Left
- 50 Pct = 50 % Life Left
- 25 Pct = 25 % Life Left
- 10 Pct = 10 % Life Left. Low Battery Light Active.
- 0 Pct = Battery Dead. Unit will lose communication at any time.

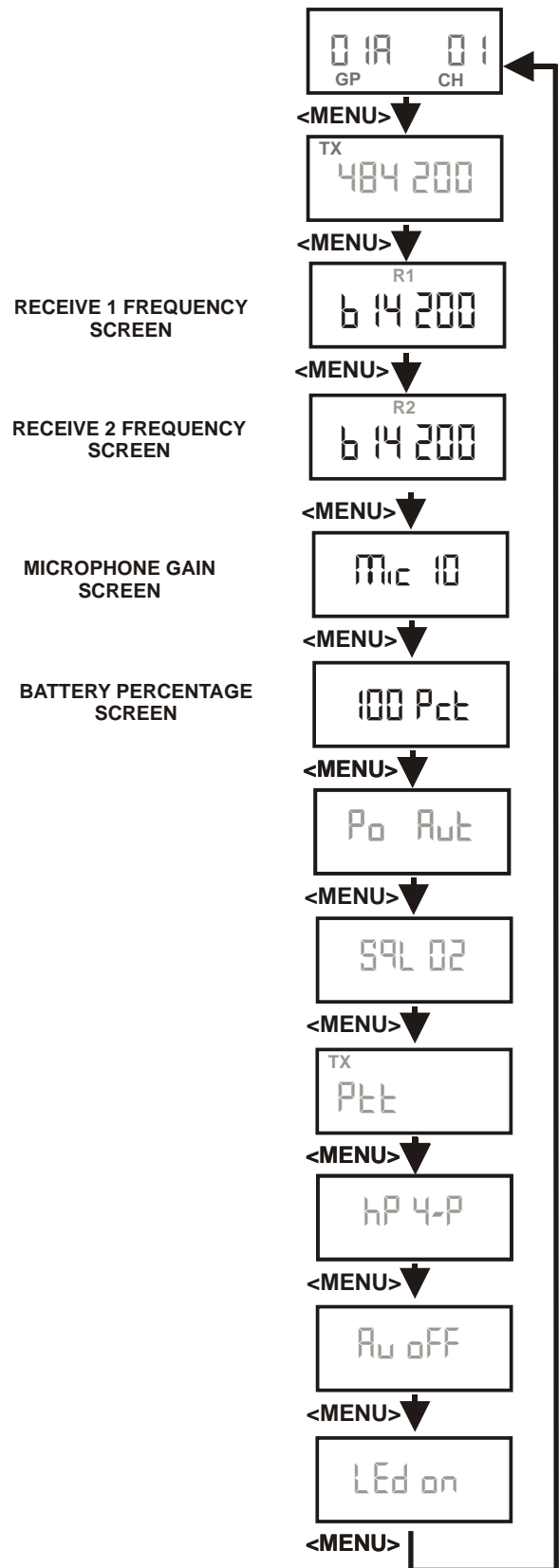


Figure 7-10  
Receive Frequencies/Microphoe Gain/  
Battery Percentage Screen

## Setting the Low Battery Alert Tone

The backpack has an audio alert tone that is sent to the headphone if the battery life reaches 10%. The tone is at 1 kHz and is heard for 0.5 seconds every 30 seconds. The tone is only heard at the backpack. The alert tone function may be turned on or off at the backpack:

### Low Battery Alert Tone On/Off

1. Press [SET] at the battery percentage screen. The screen below will appear.
2. The low battery tone option will also begin flashing.



3. Use the [UP]/[DOWN] arrow buttons to turn the option on or off.
4. Press [SET] to accept the change.



5. The screen now displays with AL or ni Flashing. Use [UP]/[DOWN] to select Al or ni for Alkaline/NiMH battery gauge calibration.
6. Press [SET] to return to the battery gauge screen.

## Transmit Power

The transmit power screen displays the current setting of the backpack transmitter's output power level. There are four settings.

### Transmit Power Settings

Auto (Default)	The backpack's transmitter adjusts its output level according to information sent to the backpack from the base station. It adjust between two levels: 5mW or 50mW.
5	The backpack is transmitting at 5 mW
50	The transmitter is at 50 mW
100	The transmitter is at 100 mW

When the unit is set to auto, base station information will tell the backpack the appropriate power setting to use based upon received signal strength level at the base station. By reducing the transmit power when possible, the battery life of the backpack can be slightly extended and intermodulation products can be reduced.

### Changing the Transmit Power Setting

1. Push [SET] at the transmit power screen. The power setting will begin flashing.
2. Select the power setting with the [UP]/[DOWN] arrow buttons.
3. Push [SET] to place the unit at the indicated setting.

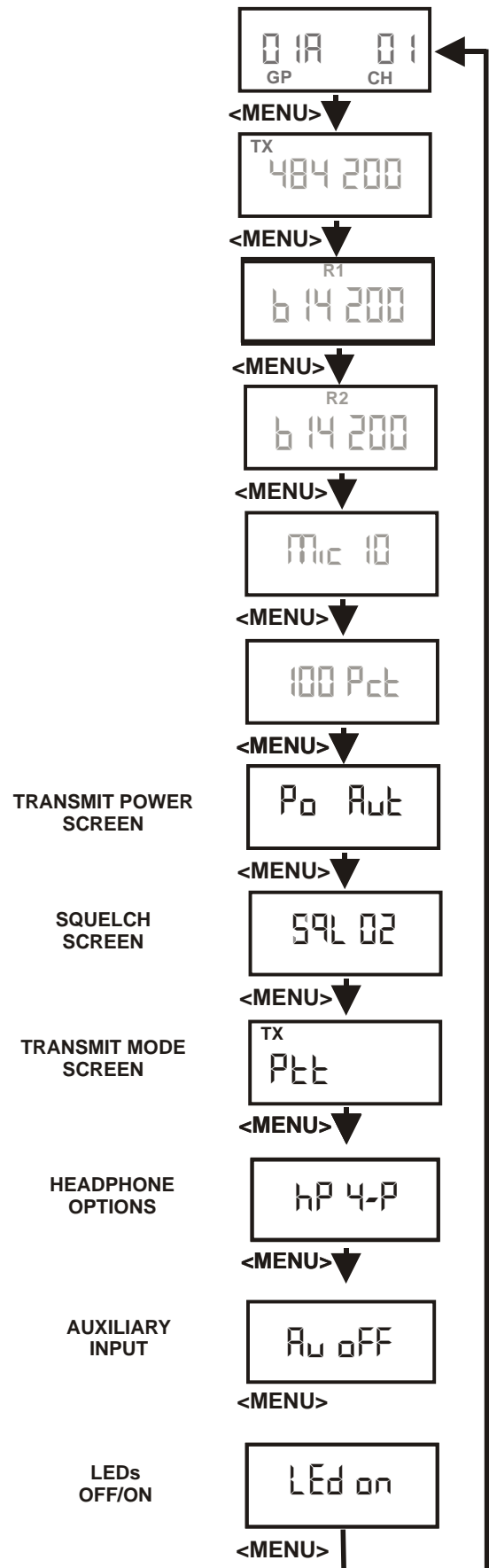


Figure 7-11  
Transmit Power/Squelch Screen

## Squelch Screen

The squelch screen allows the user to adjust the beltpack squelch level.

1. Push [SET] at the squelch screen. The squelch setting will begin flashing.
2. Use the [UP]/[DOWN] buttons to select the desired squelch setting. 1 is minimum squelch, 04 is maximum. A setting of 00 will hold the squelch open for testing. **Warning - do not set the squelch to 00 while wearing headphones with the volume turned up. White noise with no signal can be uncomfortably loud.**
3. Push [SET] to save the new squelch setting.

Squelch Lvl	Approx. SINAD	Notes
00	NA	Open
01	12	
02	20	Default
03	24	
04	NA	RSSI Lvl Squelch

Squelch Note: The beltpack employs two different types of squelches. A fast acting noise type squelch and a slower data squelch. For audio to be received by the beltpack both a good signal-to-noise audio signal (with a noise threshold set via the usersquelch settings above) and a valid data stream must be detected.

Transmit Mode	Description
Ptt	Push-to-Talk. The transmitter is always on and the talk button un-mutes the audio when on. The beltpack will respond to the audio mute commands from the base.  When a user disables the Portable Station Connect button corresponding to the beltpack the talk button at the beltpack will shut down.
Ptt Tr	Push-to-Transmit. The transmitter is off and audio muted until the talk button is on. The beltpack will ignore lockout or shutdown commands from the base.
Ptt Tr L	Push-to-Transmit Lockout Enabled. The transmitter is off and audio muted until the talk button is on. The beltpack will respond to lockout commands from the base, such as First-On-Latch-Out and Portable Station Connect disable.

## Transmit Mode Screen

The transmit mode screen is used to select the following modes:

Changing the transmit mode setting:

1. Push [SET] at the transmit mode screen. The screen will begin flashing.
2. Use the [UP]/[DOWN] buttons to select the desired mode.
3. Push [SET] to save the mode change.

## Headphone Options:

If the TR-82N has a 4 pin headset connector, the headphone should be set to "hP 4-P" (4 pin). When supplied with a 5 pin (stereo) headset connector, the settings "hP Add" should be used for Mono or "hP SEP" for channel 1 in left earpiece and channel 2 in the right earpiece. A 5 pin single-sided headset should be set to "hP 4-P".

## Auxiliary Input:

The TR-82N has a 3.5 mm mono auxiliary input jack. Audio from this jack is heard only in the belt pack headset. From the menu, press [SET] and use [UP] or [DOWN] arrows to select the Aux mode setting:

Setting	Auxiliary Input Function
Off	Aux input is disabled
1	Aux is heard with Ch1
2	Aux is heard with Ch2
12	Aux is heard with Ch 1 & 2

Press [SET] to accept setting on screen. If Aux is not Off, the next screen will display "Au NN" where NN is a 2 digit number between 0 and 15. This is the volume level setting for the aux input. Press [SET] and the 2 digits will flash. Use the [UP] and [DOWN] arrows to set Aux volume. Press [SET] again to accept the gain setting.

## LEDs Off/On

The LED off/on screen is used to disable all LEDs. This function is useful for users who do not wish to show LEDs in the dark.

1. Push [SET] at the LED on/off screen. The on/off will begin flashing.
2. Use the [UP]/[DOWN] buttons to select the desired mode.
3. Push [SET] to save the mode change.

## Software Version/ Band

The software revision and frequency band of the beltpack may be displayed from any of the main beltpack screens.

### Viewing the Software Revision and Frequency Band

1. In any of the beltpack main screens press and hold the [DOWN] button for 2 seconds.
2. The first screen indicates the frequency band of the beltpack. The second screen indicates the software revision. The screens below indicate that it is an E5 band beltpack. with 80E052 version software.
3. The screen will now revert back to the main screen.



bnd E5



80E 052

## ClearScan

ClearScan helps you find clear RF frequencies in your area. The beltpack's receiver scans all the factory defined groups and any user defined groups that have been set. The result is a list of beltpack receive groups that are clear of interference.

### Entering ClearScan

1. Press and hold [MENU] + [SET] for 2 seconds to start ClearScan
2. The beltpack display will change to "ClrScn" and the GP icon will flash.
3. After about 12 seconds, the beltpack will display the first clear group. The group number will be flashing.
4. Use the [UP]/[DOWN] buttons to display other clear groups.
5. Select a group by pressing [SET]
6. Press [MENU] to bail out without selecting a group.

Clear groups are displayed first. They are in group order. You can scroll down through groups using the [DOWN] button.

The right half of the screen will give you an indication of interference levels as you scroll through the groups.

User-defined groups that do not have a frequency defined for one of the receive channels will display a 'u' to indicate it is "undefined".

The degree of interference found for R1 and R2 will be displayed on the right two most positions on the screen. See chart below:

Interference Level	Right Half of LCD Display
None	Blank
Weak	Single bar
Moderate	Double bar
Strong	Triple bar

## Lock Out

This function allows the user to lock the top panel and menu options. The top panel buttons will still work but the talk button options can not be changed. Likewise, values on the LCD screen in the beltpack can be viewed but not changed.

### Enabling / Disabling Lock Out

1. Press and hold the [UP] and [DOWN] buttons for two seconds. The word "Loc on" will appear on the screen when lock out is active.
2. Press and hold the [UP] and [DOWN] button for two seconds again to disable lock out. The word "Loc off" will appear.

## 1st Use Default

This function sets the beltpack to Group 1A, channel 1 and leaves any user-programmed groups in memory. It will set unit to factory-defined menu settings. It will also set the "Talk" buttons to their default modes.

### Activating 1<sup>st</sup> Use

1. Press and hold the [MENU] button while powering-up the beltpack.

## Factory Reset

This function sets the beltpack to Group 1A, channel 1 and **ERASES** any user defined groups in memory. It will set a unit to factory settings. It will also set the "Talk" buttons to their default modes.

### Activating Factory Reset

1. Press and hold the [MENU] + [SET] + [UP] + [DOWN] for two seconds.

## RF Monitor Screen

Press and hold the [Menu] button for 2 seconds to display beltpack RF Status.

Press the [MENU] button again to exit RF Monitor Screen.

<b>TX Power</b>	<b>Signal Strength</b>
L <sub>0</sub> = 5mW	0 = No
h <sub>1</sub> = 50mW	1 = Very Weak
H <sub>1</sub> = 100mW	2 = Weak
	3 = Moderate
	4 = Strong
	5 = Very Strong

## Setting Beltpack ID

Several functions require the beltpack to know which base and channel it is associated with.

1. Auto Power Setting: The beltpack reduces its TX power when close to the base. Beltpack transmit power must be set to Auto.
2. Portable Station Deselect: The base can disable the TALK button of a beltpack. This shuts off the mic in PTT mode and turns off the transmitter in PT TR mode.
3. First-On-Latch Out: This locks a base receive channel so that only one beltpack can transmit on the frequency at a time. A beltpack attempting to talk on top of another beltpack on the same frequency will hear a double beep in their headset.

A beltpack will try to establish its ID automatically when its group/channel is changed. The base must be on for this to work.

To check or set beltpack ID manually:

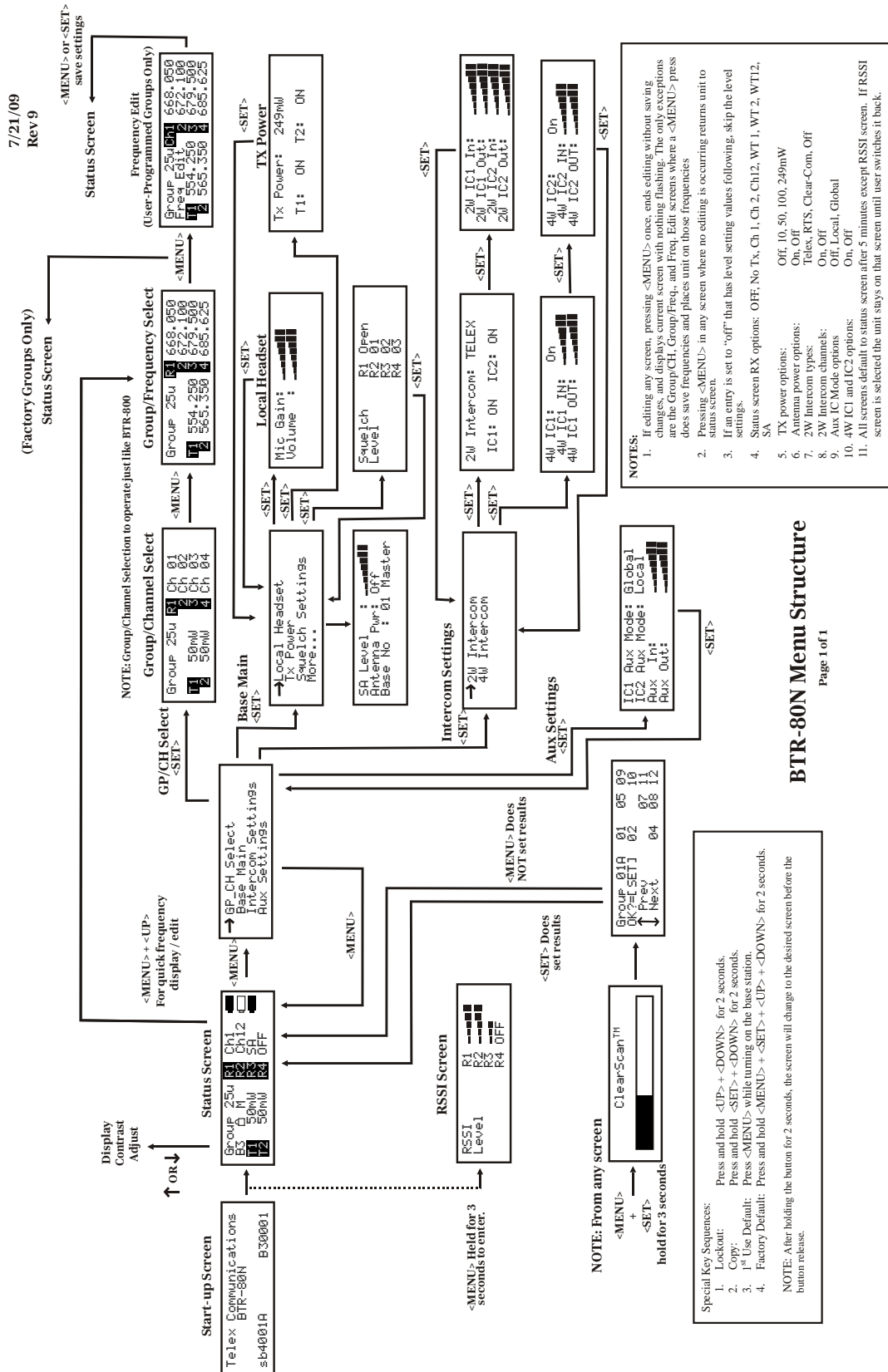
1. Press and hold [UP] for 3 seconds. The LCD will display 'id' Base '-' Receiver . For example: "id 1-3" means Base #1, Receiver #3.
2. If the LCD displays "Id---" or does not match the base and receiver the beltpack is assigned to, Auto Power, Channel Deselect and Transmit Lockout will not work correctly.
3. If the beltpack id is correct, press [MENU] to exit.
4. If the beltpack id is not correct, press [SET] and the id numbers will flash.
5. Use the [UP] or [DOWN] buttons to select a new id.
6. Press [SET] to apply the new id.

Bases with transmitters enabled are always base #1. A second base using the first base transmitters instead of its own, and properly connected to the first base thru CAN bus becomes BASE #2, etc.



# Section 8

## BTR-80N Menu Structure





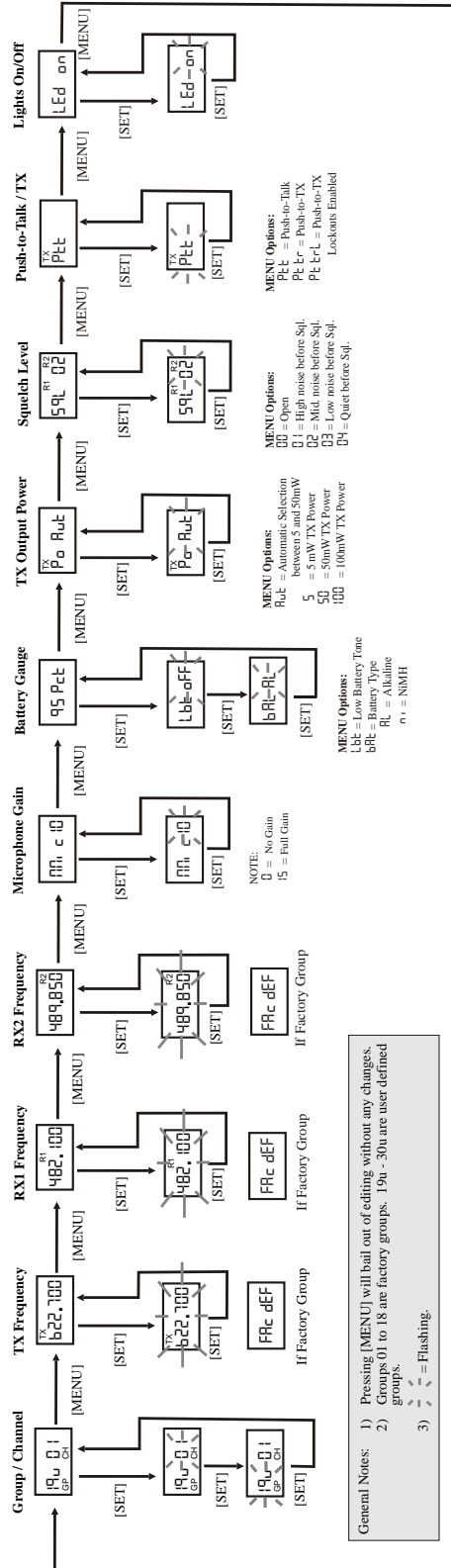


# Section 9

## TR-80N Menu Structure

5/20/2009  
Rev3

**TR-80N Backpack Screen Flowchart**



Special Key Functions									
TX Power and Receiver RSSI	Backpack Identification	Software Band Software Version	ClearScan	Talk Button Options	Stage Announce (SA)	Wireless/Talk Around (WTA)	Lockout	1 <sup>st</sup> Use Default	Factory Reset Default
Hold [MENU] for 2 seconds TX Power: [Hi] [Lo] Press [MENU] to exit to normal menus Function: Display current TX power of unit: Hi = 100mW Lo = 50mW ... = Off Display receiver strength; 0-3: 0 = Clear 5 = Strong Signal	Hold [ID] for 2 seconds [id] [i-] [i-] Press [MENU] to exit to normal menus Press [MENU] to exit to normal menus Function: View ID assigned to backpack by base station. May also be used to change backpack ID.	Hold [bnd F] for 2 seconds [bnd F] [i-] Displayed for 1 second [BCE00] [i-] Displayed for 1 second or when released Back to normal menu	Hold [CLR 5cn] + [SET] for 1 sec. [CLR 5cn] [i-] After 10 seconds backpack selected [GRp / CH] [i-] Press [SET] to Group / Channel Screen	Hold [TALK] and press [TALK] [TALK] [i-] [TALK] [i-] Function: Talk button operation. on = Talk Latch on off = Momentary	Hold [SR on] and press [SA] [SR on] [SA] [SR off] [SA] Function: Stage Announce (SA)	Hold [WTA] and press [WTA] [WTA] [i-] Options menu: on = Momentary Latch on = Latch on off = WTA disabled	Hold [Loc on] for 2 seconds [Loc on] [i-] [Loc off] [i-] Function: Menu items can be viewed but not changed when activated.	Hold [MENU] as powering-up unit [GRp / CH] [i-] Sets unit to Group 01A. Channel 01, with 01 flashing. User must set channel number. Sets Unit to defaults All user defined groups are Retained	Hold [MENU] + [SET] + [i-] + [i-] for 2 seconds [FRc rES] [i-] [GRp / CH] [i-] Sets unit to Group 01A. Channel 01, with 01 flashing. User must set channel number. Sets Unit to defaults All user defined groups are Erased

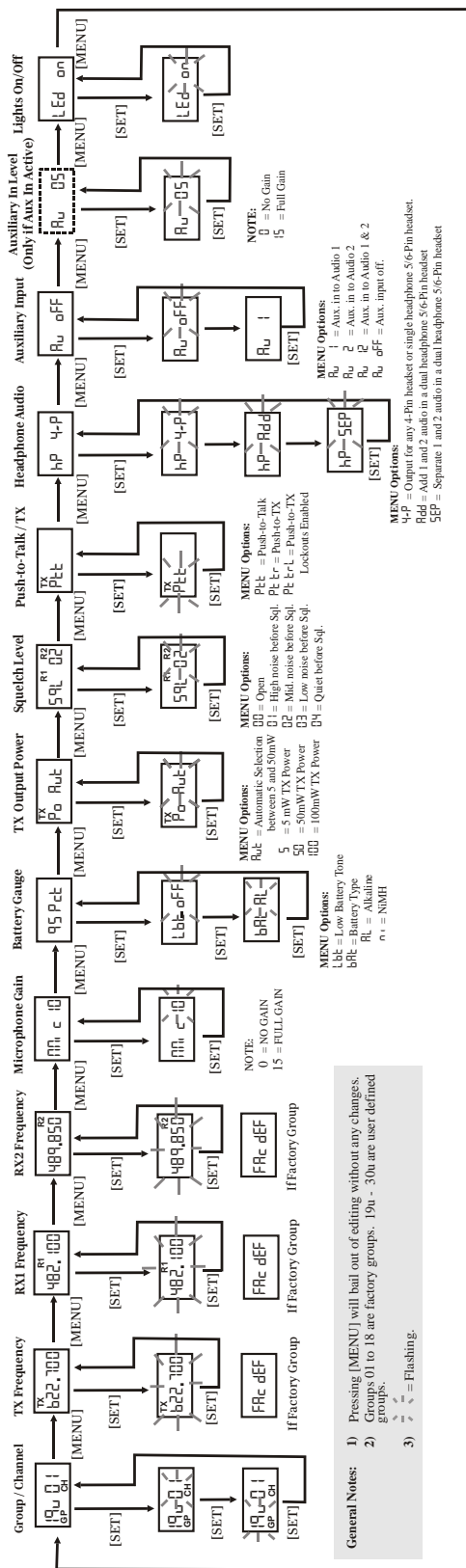


# Section 10

## TR-82N Menu Structure

5/20/2009  
Rev3

TR-82N Belpack Screen Flowchart



Special Key Functions									
TX Power and RX1 / RX2 RSSI	Belpack Identification	Software Band Software Version	ClearScan	Talk Button Options	Stage Announce (SA)	Wireless Talk Around (WTA)	Lockout	1st Use Default	Factory Reset Default
Hold [MENU] for 2 seconds Press [MENU] to exit to normal menus Function: Display current TX power of unit BH = 100mW H = 50mW L = 20mW -- = 0/0	Hold [ID] for 2 seconds Press [MENU] to exit to normal menus Function: View ID assigned to belpack by base station. May also be used to change belpack ID.	Hold [ID] for 2 seconds Displayed for 1 second Displayed for 1 second or when released Back to normal menu	Hold [MENU] + [SET] for 2 sec. After 8 seconds best group selected Back to normal menu	Hold [SET] and press [TALK] Function: Talk button operation. Len = Talk Latch on off = Talk off on = Momentary on	Hold [SET] and press [SA] Function: Stage Announce	Hold [SET] and press [WTA] Options in menu: Ph = Push button 1L = Audio 1 Latch 2L = Audio 2 Latch 12L = Audio 1 & 2 Latch off = WTA disabled 1 = Audio 1 M 2 = Audio 2 M 12 = Audio 1 & 2 M	Hold [L] + [R] for 2 seconds Function: Menu items can be changed when activated.	Hold [MENU] as powering-up unit for 1 second Sets unit to Group 01A, Channel 01A, with 01 flashing. User must set channel number. Set unit to defaults All user defined groups retained	Hold [MENU] + [SET] + [R] + [L] for 1 second Sets unit to Group 01A, Channel 01A, with 01 flashing. User must set channel number. Set unit to defaults All user defined groups erased



# Section 11

## Frequency Bands

### Frequency Bands

The BTR-80N system operates over the following frequency ranges:

- North America
  - Base TX: 482 - 608 MHz
  - Base RX: 614 - 698 MHz
- Europe
  - Base TX: 482 - 608 MHz
  - Base RX: 614 - 722 MHz

The bands, US TV channels, and frequencies are shown in Table 11-1. All bands are 18 MHz wide.

Bands F to G are always base transmit bands (beltpack receive bands). Bands 1 - 6 are always base receive bands (beltpack transmit bands). Thus an A2 base station would be comprised of an A band transmitter paired with a 2 band receiver.

### Band Pairing for Systems

All band pairs cannot be made into a system. Table 1 shows the available band pairings.

Base TX Bands	Base RX Bands
F	1, 2, 3, 4, 5, 6
H	1, 2, 3, 4, 5, 6
A	1, 2, 3, 4, 5, 6
B	2, 3, 4, 5, 6
C	3, 4, 5, 6
D	4, 5, 6
E	5, 6

**Table 11-1**  
Available band pairings

On Table 11-1 it can be seen that a C base station transmit band can be paired with 3, 4, 5, or 6 receive bands. However, a C2 unit cannot be made. This is because a certain amount of frequency separation between transmit and receive bands is required for good transmit and receive operation. If they are too close the RF performance of the system is reduced.

Band	US TV	Freq. Start	Freq. End	US TV
F	16	482	488	16
	17	488	494	17
	18	494	500	18
H	19	500	506	19
	20	506	512	20
	21	512	518	21
A	22	518	524	22
	23	524	530	23
	24	530	536	24
B	25	536	542	25
	26	542	548	26
	27	548	554	27
C	28	554	560	28
	29	560	566	29
	30	566	572	30
D	31	572	578	31
	32	578	584	32
	33	584	590	33
E	34	590	596	34
	35	596	602	35
	36	602	608	36
1	37	608	614	37
	38	614	620	38
	39	620	626	39
2	40	626	632	40
	41	632	638	41
	42	638	644	42
3	43	644	650	43
	44	650	656	44
	45	656	662	45
4	46	662	668	46
	47	668	674	47
	48	674	680	48
5	49	680	686	49
	50	686	692	50
	51	692	698	51
6	52	698	704	52
	53	704	710	53
	54	710	716	54
EURO ONLY	55	716	722	55

**Table 11-2** -Band Names, Frequencies, and US TV Channels

## Frequency Plan

There are 48 groups in a BTR-80N system. The 48 groups are divided up into 36 factory-defined groups and 12 user defined groups. A group referenced to a base station is comprised of two TX channels and up to 12 RX channels.

**User-defined groups** are blank initially and allow the user to enter their own frequencies.

**Factory-defined groups** are composed of frequencies that cannot be modified by the user. The 36 groups are composed of the following:

- 9 Triplet groups
  - Groups 1a to 9c
- 9 Single groups
  - Groups 10-18

The factory groups are organized in different ways to provide flexibility to the user on selecting frequencies. A group is composed of intermodulation free frequencies. The triplet groups may be used together for up to three systems that are intermodulation coordinated. For example, three intermodulation coordinated systems may be set up by using the following groups and channels:

- System A = Group 1a, channels: 1, 2, 3, 4
- System B = Group 1b, channels: 5, 6, 7, 8
- System C = Group 1c, channels: 9, 10, 11, 12

A group also contains frequencies within different combinations of the TV channels. The user then can select a group that is clear of broadcast TV channels in the area by selecting a group(s) that doesn't use those channels.

Table 11-3 indicates how the factory defined groups used the three TV channels for TX and three TV channels for receive. These plans are based upon US broadcast TV channels. A darkened TV channel indicates the group has frequencies in that channel. The white TV channel indicates the group has no frequencies in that TV channel. For example, Group 1A uses at least one frequency from each of the three TV channels for RX and only the 1st TV channel for TX. However group 18 uses only the third TV channel for TX and RX.

	Base TX Freq.			Base RX Freq.		
	TV1	TV2	TV3	TV4	TV5	TV6
1a	Dark	Dark	Dark	Dark	Dark	Dark
1b	Dark	Dark	Dark	Dark	Dark	Dark
1c	Dark	Dark	Dark	Dark	Dark	Dark
2a	Light	Dark	Light	Dark	Dark	Dark
2b	Light	Dark	Light	Dark	Dark	Dark
2c	Light	Dark	Light	Dark	Dark	Dark
3a	Light	Light	Dark	Dark	Dark	Dark
3b	Light	Light	Dark	Dark	Dark	Dark
3c	Light	Light	Dark	Dark	Dark	Dark
4a	Dark	Light	Light	Dark	Dark	Dark
4b	Dark	Light	Light	Dark	Dark	Dark
4c	Dark	Light	Light	Dark	Dark	Dark
5a	Light	Dark	Light	Dark	Dark	Dark
5b	Light	Dark	Light	Dark	Dark	Dark
5c	Light	Dark	Light	Dark	Dark	Dark
6a	Light	Light	Dark	Dark	Dark	Dark
6b	Light	Light	Dark	Dark	Dark	Dark
6c	Light	Light	Dark	Dark	Dark	Dark
7a	Dark	Light	Light	Dark	Dark	Dark
7b	Dark	Light	Light	Dark	Dark	Dark
7c	Dark	Light	Light	Dark	Dark	Dark
8a	Light	Dark	Light	Dark	Dark	Dark
8b	Light	Dark	Light	Dark	Dark	Dark
8c	Light	Dark	Light	Dark	Dark	Dark
9a	Light	Light	Dark	Dark	Dark	Dark
9b	Light	Light	Dark	Dark	Dark	Dark
9c	Light	Light	Dark	Dark	Dark	Dark
10	Dark	Light	Light	Dark	Dark	Dark
11	Light	Dark	Light	Dark	Dark	Dark
12	Light	Light	Dark	Dark	Dark	Dark
13	Dark	Light	Light	Dark	Dark	Dark
14	Light	Dark	Light	Dark	Dark	Dark
15	Light	Light	Dark	Dark	Dark	Dark
16	Dark	Light	Light	Dark	Dark	Dark
17	Light	Dark	Light	Dark	Dark	Dark
18	Light	Light	Dark	Dark	Dark	Dark

**Table 11-3 - Groups and TV Channel Used.**  
**Dark = TV used, Light = TV not used.**



# Section 12

## Troubleshooting

Reread the sections of this manual to make sure you have completed system set-up properly.

If you are unable to solve the problem, contact the dealer from whom you purchased the system for assistance.

PROBLEM	SOLUTION
<b>DISTORTION</b> - System's audio quality seems distorted at medium to high input levels.	Reduce microphone gain by adjusting microphone gain control in software.
<b>HISS</b> - System seems to produce a "hiss" which is undesirable.	Check the gain setting on all beltacks and the base. They may be too low or too high. Check to make sure you are still well within range of the base station.
<b>LOW OUTPUT</b> - System produces a low output level.	Check the gain setting on both the beltacks and the base. They may be too low.
<b>FEEDBACK</b> - Moving around area of use produces "squeal" or "howl" in various locations using ext. speakers.	Reduce the gain settings on both the beltacks and the base. They may be too high. If in 2-wire mode, the intercom channel your are on may be unloaded.
<b>DROPOUTS</b> - When moving around the area of use there seems to be locations where the signal "swooshes" or completely disappears.	Make sure both antennas on the base and beltack are connected and follow the location suggestions. Change the location of the base unit and antennas or avoid the bad areas with the remote beltacks.
<b>INTERFERENCE</b> - System picks up signals other than wireless intercoms.	<p>Make sure that all the Telex beltack(s) are on. If there are any unused receivers at the base, turn the audio off from those receivers by deselecting the appropriate "Portable Station Connect" button.</p> <p>If problems persist with the beltack on, you will probably need to change the group. Make sure the base and beltack match after any Group/Channel change.</p>
<b>NO AUDIO</b> from BASE or BELTPACK headsets.	Check Transmitter setting on base and beltack. Check talk LED to make sure it is on. Make sure beltack batteries are OK.





# Section 13

## Battery Information

---

Improper battery selection, use, installation and care are the cause of numerous wireless system failures.

**Alkaline Batteries:** Alkaline batteries such as Mallory's DURACELL® or Eveready's ENERGIZER® provide the most reliable operation in wireless transceivers.

**The use of low cost carbon-zinc batteries is NOT recommended.**

**Nickel-Metal Hydride Batteries:** These batteries can save you money in the long run, as they can be recharged. Typical battery life is greater than the length of time alkaline batteries last.

### Cold Temperatures and Batteries

The battery life times listed in this section are at room temperature. Alkaline and Nickel-Metal Hydride batteries service hours falls off significantly at low temperatures due to battery chemistry. Alkaline batteries typically have less than half their room temperature service life if used at freezing 32° F (0° C). Due to the service hours reduction of Alkaline and Nickel Metal Hydride batteries at low temperature the user will need to change batteries more often.

Another solution is using Lithium AA cells if belt packs are to be used in very cold temperatures. Lithium batteries, like the Energizer® E<sup>2</sup> Lithium AA cells, are excellent batteries at cold temperatures. At the temperatures of 15° F (-9° C), Lithium AA cells will last about 7 times longer than Alkaline batteries. that equates to 2 hours for Alkaline vs 14 hours for Lithiums. However, the tradeoff is Lithiums cost more and are less friendly to the environment than alkalines.

### Battery Life:

#### TR-80N

Alkaline, 9-10 hours typical  
Nickel Metal Hydride, 10-11 Hours typical

#### TR-82N

Alkaline, 6-7 hours typical  
Nickel Metal Hydride, 8-9 Hours typical

### WARNING:

Do not place an alkaline TR battery pack in any battery charger. Severe charger and battery pack damage may result.

Energizer® is a registered trademark of Union Carbide Corporation.  
Duracell® is a registered trademark of Duracell Inc.



# Section 14

## 2-Wire Systems Specifications

**RTS**

Input Impedance:.....200Ω

Output Level:.....0.775 Vrms nominal

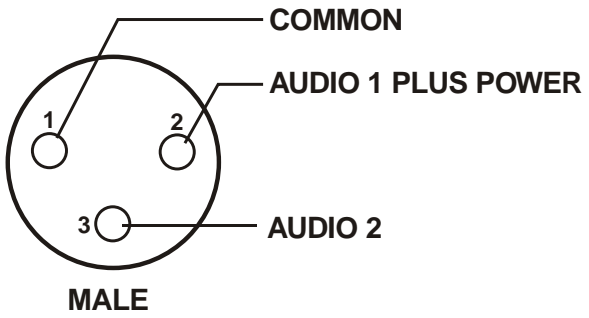
Bridging Impedance:.....>10kΩ

Call Signaling:

    Send: .....20kHz 100 Hz, 240 mVrms

    Receive: .....20kHz ±800 Hz, 100 mVrms

Power Voltage: .....28.0 VDC nominal



**MALE**

**AudioCom/Telex**

Input Impedance:.....300Ω

Output Level:.....1.0 Vrms nominal

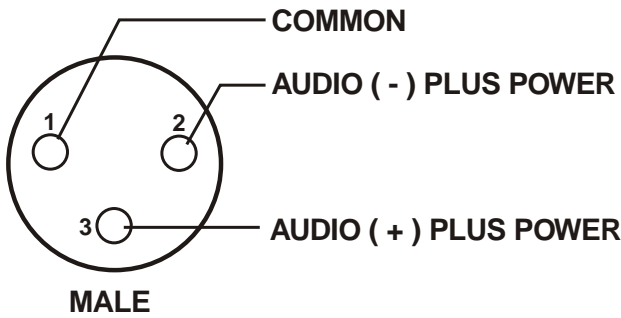
Bridging Impedance:.....>10kΩ

Call Signaling:

    Send: .....20kHz ± 100 Hz, 05 mVrms

    Receive: .....20kHz ±800 Hz, 100 mVrms

Power Voltage: .....24.0 VDC nominal



**MALE**

**Clear-Com**

Input Impedance:.....200Ω

Output Level:.....1.0 Vrms nominal

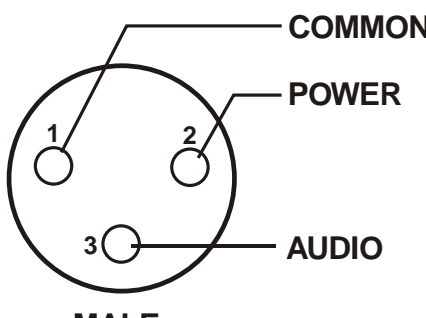
Bridging Impedance:.....>10kΩ

Call Signaling:

    Send:.....12 3 VDC

    Receive: .....4 VDC Minimum

Power Voltage: .....30.0 VDC nominal



**MALE**



## Certification Information

### FCC

The Telex BTR-80N, TR-80N, and TR-82N Transmitter/receiver are type accepted under United States Federal Communications Commission Part 74. Licensing of Telex equipment is the user's responsibility and licensibility depends on the user's classification, users application, and frequency selected. Telex strongly urges the user to contact the appropriate telecommunications authority for any desired clarification.

This device complies with Part 15 of the FCC Rules. Operation is subject to the condition that this device does not cause harmful interference.

**CAUTION:** Changes or modifications made by the user could void the user's authority to operate the equipment.

The beltpack is intended to be worn on the belt of the user with both antenna's vertical for best operating range and performance. Placing the beltpack in other locations on the body may reduce performance and void the user's authority by the FCC to operate the equipment.

### Mandatory Safety Instructions to Base Station Installers and Users

1. Use only manufacturer or dealer supplied antenna. Antenna minimum safe distance, for a base-station, as set by the FCC is 20cm. Antenna gain: zero dBd referenced to a dipole.
2. The FEDERAL COMMUNICATIONS COMMISSION has adopted a safety standard for human exposure to RF (Radio Frequency) energy, which is below the OSHA (Occupational Safety and Health Act) limits.
3. To comply with current FCC RF Exposure limits, the antenna must be installed at or exceeding the minimum safe distance show here, and in accordance with the requirements of the antenna manufacturer or supplier.
4. Antenna substitution: Do Not substitute any antenna for the one supplied by or recommended by the manufacturer or radio dealer. You may be exposing person or persons to harmful radio frequency radiation. You may contact your radio dealer or the manufacturer for further instructions.
5. **WARNING:** Maintain a separation distance from the antenna to person(s) of at least 20cm.

You, as the qualified end-user of this radio device must control the exposure conditions of bystanders to ensure that the minimum separation distance (above) is maintained between the antenna and nearby persons for satisfying RF Exposure compliance.

The operation of this transmitter must satisfy the requirements of the General Population/Uncontrolled Exposure Environment for work-related use. Transmit only when person(s) are at least the minimum distance from the properly installed, externally mounted antenna.

### Industry Canada

The Telex BTR-80N, TR-80N, TR-82N transmitter/receiver are certified to Industry Canada RSS-123 rules

Licensing of Telex equipment is the users responsibility and licensability depends upon the user's classification, user's application and frequency selected. Telex strongly urges the user to contact the appropriate telecommunicatins authority for any desired clarification.

**CAUTION:** Any changes or modifications made to the above equipment could void the user's authority to operat the equipment.



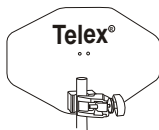
# Section 16

## Accessories and Replacement Parts

### ALP-700

450-760MHz Bi-directional Log Periodic Antenna

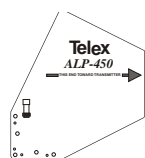
**P.N. 301824000**



### ALP-450

450-900 MHz Log Periodic Antenna  
Includes mounting hardware and 10 feet (3 meters) coaxial cable with TNC connectors

**P.N. 71147000**



### ALP-600

520-760 MHz Bi Directional Log Periodic Antenna Includes mounting hardware and 10 feet (3 meters) of coaxial cable with TNC Connectors

**P.N. 878896**

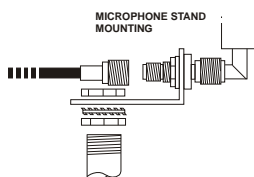


### Antenna Cables

Special low loss antenna cables with TNC Connectors

Model No.	Length	Part No.
CXU-10	10 Ft. (3 meter)	690419
CXU-25	25 Ft. (7.6 meter)	71151-025
CXU-50	50 Ft. (15 meter)	71151-050
CXU-75	75 Ft. (23 meter)	71151-075
CXU-100	100 Ft. (30 meter)	71151-100

### AB-2



**Bracket** for 1/2 wave Antenna with 10 ft. of coax-

**P.N. 71138000**

### BTR Power Cords

North America.....P.N. 550024013  
U.K.....P.N. 550024002  
European .....P.N. 550014000  
Australian.....P.N. 550024018

### BTR Intercom Dummy Load

Telex type.....P.N. 878935  
RTS type.....P.N. 878990

### 2TX80N Dual transmit connector kit

for BTR-80N .....P.N. PRD000224000

**SA Relay plug adapter**.....P.N. 2862046

**DC-LP Locking D.C plug**.....P.N. 650102

**BLC, BTR-80N Link Cable**.....P.N. PRD000223000

### CTC, BTR-80N

CAN BUS Termination Cable.....P.N. PRD000223001

### CAN-T, BTR-80N

CAN BUS 120 Ohm Termination .....P.N. PRD000223002

### BP-700 TR Battery pack, alkaline

(batteries not included) .....P.N. 71315-000

### BP-800NM Rechargeable 2200mAh

Nickle-metal hydride battery pack.....P.N. 71315-002

### BC-800NM4

Four Slot "Smart" Charger with Four BP-800NM battery packs  
North America..PRD000070008  
Euro .....PRD000070009

### BC-800NM

Single Slot "Smart" Charger with BP-800NM battery pack  
North America..PRD000070006  
Euro.....PRD000070007



**Beltpack:**  
**1/4 - Wave antennas**



Part No.	Band Color	Frequency Coverage of Antenna	Beltpack RX Band						Beltpack TX Band							
			F	H	A	B	C	D	E	1	2	3	4	5	6	
879220-1	Violet	425.0 - 488.0 MHz														
879220-2	Black	485.0 - 553.9 MHz	X	X	X	X										
879220-3	Yellow	554.0 - 635.9 MHz					X	X	X							
879220-4	Green	636.0 - 725.9 MHz								X	X	X	X	X	X	
879220-5	Red	726.0 - 826.0 MHz														
879220-6	Blue	826.0 - 930.0 MHz														

**Base Station:**  
**Flexible Ground Independent Dipole Antennas**



Model No.	Part No.	Band Color	Frequency Coverage of Antennas	Base TX Band						Base RX Band						
				F	H	A	B	C	D	E	1	2	3	4	5	6
FA-RW	EML000106RW	Red/White	470-550 MHz	X	X	X										
FA-YW	EML000106YW	Yellow/White	525-610 MHz				X	X	X	X						
FA-GW	EML000106GW	Green/White	610-710 MHz								X	X	X	X	X	
FA-BW	EML000106BW	Blue/White	710-880 MHz													X

**Base Station:**  
**1/2-Wave Ground Plane Independent Antenna**



Model No.	Part No.	Band Color	Frequency Coverage of Antenna	Base TX Band						Base RX Band						
				F	H	A	B	C	D	E	1	2	3	4	5	6
CLA-1	870658-1	Blue	520 - 564.9 MHz				X									
CLA-2	870658-2	Yellow	565 - 614.9 MHz						X	X						
CLA-3	870658-3	Red	615 - 659.9 MHz								X	X	X			
CLA-4	870658-4	White	660 - 689.9 MHz											X		
CLA-5	870658-5	Green	690 - 724.9 MHz												X	X
CLA-6	870658-6	Orange	725 - 760 MHz													
CLA-8	870658-8	Purple	796 - 865 MHz													
CLA-10	870658-10	Tan	470 - 506 MHz	X	X											
CLA-11	870658-11	Pink	515 - 548 MHz			X										
CLA-12	870658-12	Brown	542 - 575 MHz					X								

**TELEX**<sup>®</sup>

---

TELEX COMMUNICATIONS, INC. • 12000 Portland Ave. South, Burnsville, MN 55337.

PN LIT000125TX Rev. A

August 2009

Made in U.S.A.